

Operating Instructions

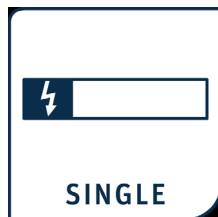

F01045y



Smart Discharging System

Series SDS discharging bar for 24 V DC

BA-en-2080-2403



List of contents

| | | |
|----------|---|-----------|
| 1 | Outline of appliance | 6 |
| 2 | Safety | 8 |
| 2.1 | Identification of risks and hazards | 8 |
| 2.2 | Proper use and range of applications | 8 |
| 2.3 | Work and operational safety | 9 |
| 2.4 | Contact protection | 12 |
| 2.5 | Inspection of the protective resistors - contact protection | 13 |
| 2.6 | Technical advance | 13 |
| 3 | Installation and assembly | 14 |
| 3.1 | Assembling the discharging bar | 14 |
| 3.2 | Connecting supply voltage | 17 |
| 3.3 | Ground connection | 17 |
| 3.4 | Plug connection | 16 |
| 3.5 | Use of the Eltex signal cable KS | 20 |
| 3.6 | CANopen® field bus interface | 21 |
| 4 | Operation | 22 |
| 4.1 | Startup | 22 |
| 4.2 | Function monitoring | 22 |
| 4.3 | Function control | 24 |
| 4.4 | Setting the node address | 24 |
| 4.5 | Changing the CAN baud rate | 25 |
| 4.6 | Releasing the high voltage | 26 |
| 4.7 | Clearing errors and warnings | 26 |
| 5 | Maintenance | 27 |
| 6 | Troubleshooting | 29 |
| 6.1 | Error messages | 30 |
| 6.2 | Warning messages | 37 |
| 7 | Technical specifications SDS | 39 |
| 8 | Dimensions | 41 |
| 9 | Spare parts and accessories | 43 |
| | Declaration of Conformity | 46 |
| | UKCA Conformity | 47 |

Dear customer,

The high performance discharging bar SDS are used mainly in cases where disruptive static charges need to be eliminated over medium distances.

The advantages of the SDS discharging bars:

- integrated high voltage generation
- high output voltage for medium discharge range
- a long life emission tip realized with an optimized high-performance material of the emission tip
- shockless - no danger of electrical shock to personnel
- robust, compact design
- easy installation
- easy handling
- profile easy to clean
- function and malfunction monitoring of the system with fault signal output
- crosslinking of the bar in CANopen® networks

Please read the operating instructions carefully before operating the unit. This will help you prevent personal injuries and damage to property.

Please give us a call if you have any suggestions, proposals or ideas for improvements. We greatly appreciate the feedback from the users of our appliances.

1. Outline of appliance

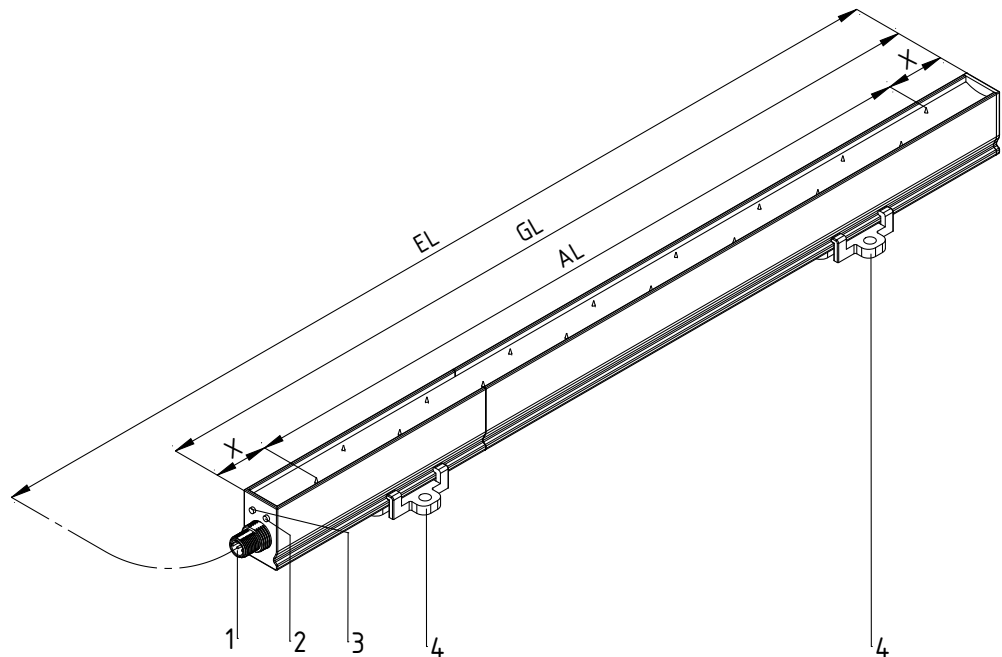

- 1 Connector M12
- 2 Operating display Status-LED
- 3 Operating display CANopen®-Status-LED
- 4 Bracket

EL = Installation length

AL = Active length

GL = Total length

X = Distance first resp. last tip (depending on the operating space)

Fig. 1:
Overview
SDS
discharging bar

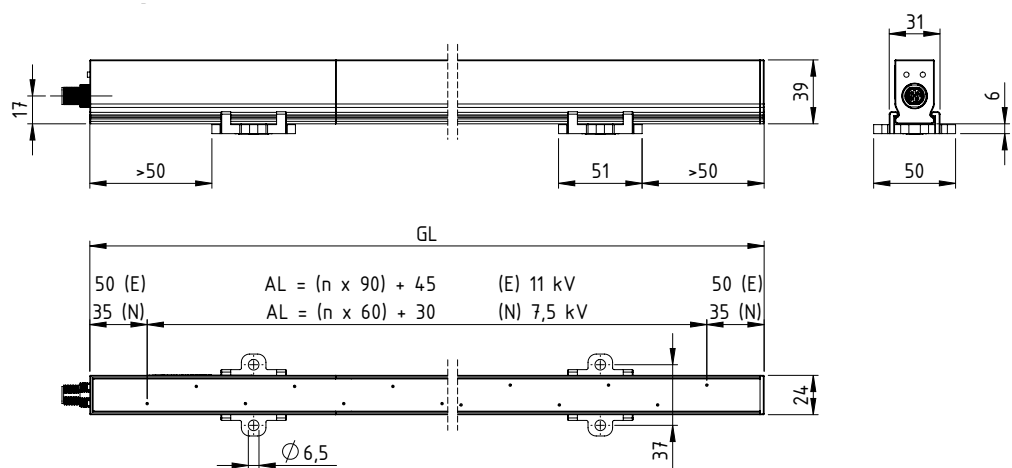

Fig. 2:
SDS
discharging bar

Z-114897y_1

Z-114897y_2

Variants

The discharging bar SDS is available in 4 different variants. Different configurations with regard to operating range and/or interface are available. The different variants are identified with their first two letters in the reference code of the SDS discharging bar: the first letter marks the operating range, while the second letter marks the interface configuration.

The use of the SDS/N and SDS/E discharging bars depends on the material to be discharged, the process speed, the distance to the material and the required residual charge. Below you will find the values at which the SDS discharging bar produces optimum results. For applications with a greater distance or the discharge of highly charged substrates we recommend suitable discharging bars of the Eltex product portfolio.

- Operating range

| | |
|-------|---|
| SDS/N | close range: bar insert: min. 100 mm - 150 mm active length: 330 mm - 3,990 mm grid spacing: 60 mm |
|-------|---|

| | |
|-------|--|
| SDS/E | enlarged range: bar insert: min. 150 mm - 300 mm active length: 315 mm - 3,915 mm grid spacing: 90 mm |
|-------|--|

- Interface

| | |
|--------|------------------------------|
| SDS/_S | bar with fault signal output |
| SDS/_C | bar with CANopen® |

2. Safety

The units have been designed, built and tested using state-of-the-art engineering, and have left the factory in a technically and operationally safe condition. If used improperly, the units may nevertheless be hazardous to personnel and may cause injury or damage. Read the operating instructions carefully and observe the safety instructions.

For warranty conditions, please refer to the General Terms and Conditions (GTC), see www.eltex.de.

2.1 Identification of risks and hazards

Possible risks and hazards resulting from the use of the units are referred to in these operating instructions by the following symbols:



Warning!

This symbol appearing in the operating instructions refers to operations which, if carried out improperly, may result in serious personal injuries.



Caution!

This symbol appearing in the operating instructions refers to operations which, if carried out improperly, may result in damage to property.

2.2 Proper Use and range of applications

The Series SDS discharging bars must be used only for discharging static charges from material surfaces. Other uses are not permitted.

The manufacturers will not assume any liability and warranty if the units are used improperly or used outside the intended purpose.

Modifications or changes made to the devices are not permitted.

Use only original Eltex spare parts and equipment.

Range of applications for the SDS discharging bar

The use of the SDS/N and SDS/E discharging bars depends on the material to be discharged, the process speed, the distance to the material and the required residual charge. Below you will find the values at which the SDS discharging bar produces optimum results. For applications with a greater distance or the discharge of highly charged substrates we recommend suitable discharging bars of the Eltex product portfolio.

The SDS discharging bar has been designed for use in the medium distance range and is to be operated as follows:

SDS/N area: min. 100 mm - 150 mm

SDS/E area: min. 150 mm - 300 mm

For use in applications involving slow to medium speeds, the maximum process speed for the discharging bars is

SDS/N 10 m/s and
SDS/E 5 m/s



Caution!

Falling below the minimum distance

If mounted too closely to the substrate to be discharged, the SDS discharging bar may be ineffectively by high electrical fields; the even discharging of the substrate across the whole width is no longer possible; the results are lamellar or strip-shaped charges.

Discharge of highly charged substrates

The SDS discharging bar is not suitable for discharging highly charged substrates (such as are generated by fast-running webs, for instance). An optimal discharge is not possible, and use of the SDS discharging bar may cause malfunctions. Please use a suitable discharging bar, e.g. the Eltex R50 discharging bar, in applications such as these.

Exceeding the maximum working distance

If the distance between the SDS discharging bar and the substrate is too great, the discharging effect on the substrate may be compromised.

Permanent protective grounding

Once the bars are installed, they must **always** be grounded regardless of the operating condition. Failure to take this into account will destroy the bar.

2.3 Work and operational safety



Warning!

Carefully observe the following notes and the complete [chapter 2 "Safety", page 8!](#)

- Before carrying out repairs, cleaning or maintenance work and before resetting after malfunctions, switch off the power supply and disconnect the mains supply voltage (see [chapter 5 "Maintenance", page 27](#), [chapter 6 "Troubleshooting", page 29](#)).
- Before carrying out any work involving the units, the machine which has the units fitted must not be in operation (see [chapter 5 "Maintenance", page 27](#), [chapter 6 "Troubleshooting", page 29](#)).
- Any work involving the units must be carried out by qualified electricians (see [chapter 5 "Maintenance", page 27](#), [chapter 6 "Troubleshooting", page 29](#)).

- The bars passively absorb energy from the moving substrate web. The high voltage cable must be plugged in or grounded to the power supply. If the high voltage cable is disconnected, the plug is live (high voltage) and applies with full power on the plug; this may cause a spark discharge and may lead to a risk of injury. Disconnected high voltage plugs are not permitted or have to be grounded (see [chapter 5 "Maintenance", page 27](#)).
- Evenly space the brackets across the full length; only plastic assembly material may be used (see [chapter 3.1 "Assembling the SDS discharging bar", page 14](#)).
- The bar must be mounted such that mechanical damage to the bar tips is ruled out (see [chapter 3.1 "Assembling the SDS discharging bar", page 14](#)).
- When routing the cable, select the attachment points such that mechanical damage to the cable (e.g. chafing against rotating machine parts) is ruled out (see [chapter 3.1 "Assembling the SDS discharging bar", page 14](#)).
- In applications involving moving bars, the cable must be attached such that there is no cable movement near the connection zone of the bar (see [chapter 3.1 "Assembling the SDS discharging bar", page 14](#)).
- Once the bars are installed, they must **always** be grounded regardless of the operating condition. Failure to take this into account will destroy the bar (see [chapter 3.1 "Assembling the SDS discharging bar", page 14](#)).
- The discharging bar SDS must be positioned such that the distance between the emission tips and the object to be discharged is smaller than the distance to the grounded machine components (see [chapter 3.1 "Assembling the SDS discharging bar", page 14](#)).
- To ensure that no voltage is supplied to the bars when the material web is at rest, enabling the supply voltage to the unit via machine contact is recommended. If the material web is at rest, or if the machine is not in operation, no high voltage is supplied to the bars in this case. When operating the bar using CANopen® it is advisable to block the enable function of the high voltage via the field bus while the machine is at standstill (see [chapter 3.2 "Connecting supply voltage", page 17](#)).
- A shielded cable must be used when operating the bar. The shield must make close surface contact with ground potential at a suitable point. Make sure that the link between the shield and the ground potential is as low-resistance as possible (see [chapter 3.3 "Ground connection", page 17](#)).
- When connecting the plug, make sure that the contacts are connected with the correct signals and the correct polarity of the supply voltage. Incorrect connection may irretrievably damage the bar (see [chapter 3.4 "Plug connection", page 18](#)).

- When using the variant with CANopen®, a cable with a surge resistance of 120 Ohm suitable for CAN bus networks must be used for both bus leads; this is the only way the proper function of the CAN network can be assured.
The maximum cable lengths specified in CiA 303-1 as factor of the transmission speed must be observed for the whole network and for the individual spur lines (see [chapter 3.4 "Plug connection", page 18](#)).
- The discharging bars must be operated with a 24 V DC power supply (see [chapter 4 "Operation", page 22](#)).
- Once all the connections have been correctly made, the system is operational and the supply voltage can be switched on (see [chapter 4 "Operation", page 22](#)).
- When integrating the SDS/xC bar into the network, it is important to ensure that all nodes in the CANopen® network are operated with the same baud rate, otherwise there may be communication errors at individual devices or, at worst, the entire network may crash (see [chapter 4.5 "Changing the CAN baud rate", page 25](#)).
- Check the units at regular intervals and before startup for any damage. Any damaged components must be repaired or replaced before continuing to operate the unit, or the units must be disabled.
- Make sure that the units are clean at all times.
Dirt results in malfunctions and in premature wear of the units.
- Do not touch the emission tips - risk of injury.
If the high voltage supply is connected, reflex responses to electrical irritation can lead to secondary accidents; the charging bar as such is safe to touch. If contact is made, the energy transferred is so low that there is no risk of injury.
- Potential risk for wearers of cardiac pacemakers:
Moving the chest closer than 3.5 cm to the emission tips of the discharging bars or making surface contact with several emission tips (touching a single tip is not critical) can result in a temporary switchover of the cardiac pacemaker into the fault mode. Permanent proximity or contact can therefore cause severe problems.
If it is likely that the chest of such a person comes closer than 3.5 cm to the emission tips of the discharging bar, or if several emission tips are touched at the same time, the appropriate warning notices must be displayed.
- During operation of the devices, small amounts of ozone (O₃) may be produced at the emission tips depending on a variety of boundary conditions such as site of installation, bar voltage and current, air circulation, etc.
If the maximum allowable concentration of ozone must be observed at the site of installation of the bar, the concentration must be measured on site.

2.4 Contact protection

The site of installation and/or use of the units is outside the control of Eltex, contact protection against inadvertent contact of the bars and of live components by personnel as specified by the employer's liability insurance association may have to be provided (e.g. DGUV V3 in Germany). Contact protection devices made of conductive material must be grounded.

2.5 Inspection of the protective resistors - contact protection

The function and the appearance of the protective resistors must be inspected at regular intervals. The inspection intervals are specified in the accident prevention regulations, as amended (e.g. in Germany DGUV V3).

When inspecting the protective resistance of the individual ionization tips, the first tips seen from the connector (variant SDS/N = 4 tips, SDS/E = 3 tips) are decoupled via a common resistor; this means that only one tip of the jointly decoupled tips to the remaining tips can be inspected.

The function of the series resistors between two ionization tips of the same polarity must be checked using a suitable measuring device. The test voltage must be 1,000V. The measured resistance between the first combined decoupled tips and the single decoupled tips must not fall below 294 MOhm and not exceed 386 MOhm. The resistance between the single decoupled tips must not fall below 192 MOhm and not exceed 288 MOhm.

Number of jointly decoupled tips for the different variants:

- SDS/N
4 jointly decoupled tips for each row of tips
- SDS/E
3 jointly decoupled tips for each row of tips

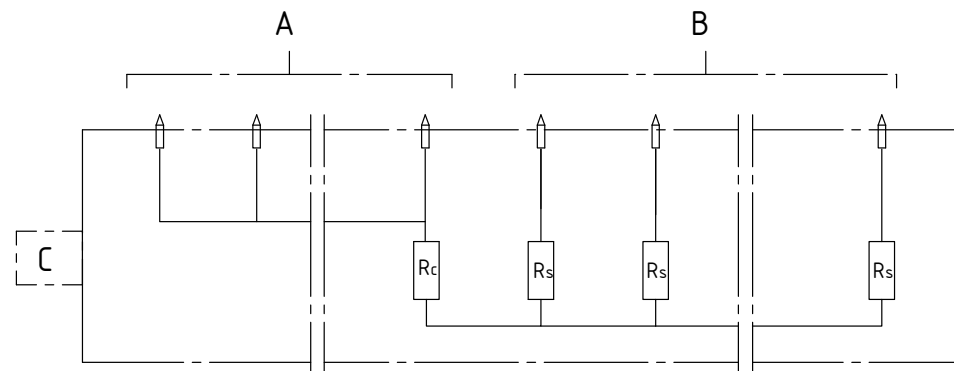

Fig. 3:
Overview
single decoupled /
jointly decoupled
tips

- A: jointly decoupled tips with $R_C = 220 \text{ MOhm}$
- B: single decoupled tips with $R_S = 120 \text{ MOhm}$
- C: Connection / plug-in module

Z-115516y_3

2.6 Technical advance

The manufacturer reserves the right to make changes to the technical specifications without prior notice in order to adapt the units to state-of-the-art engineering. Eltex will provide the latest information on any changes or modifications in the operating instructions on request.

3. Installation and assembly

3.1 Assembling the SDS discharging bar

Attach the Series SDS discharging bars with special brackets to the machine wall. For easier installation we recommend using the assembly material offered by Eltex. Fig. 4 shows the installation principle.

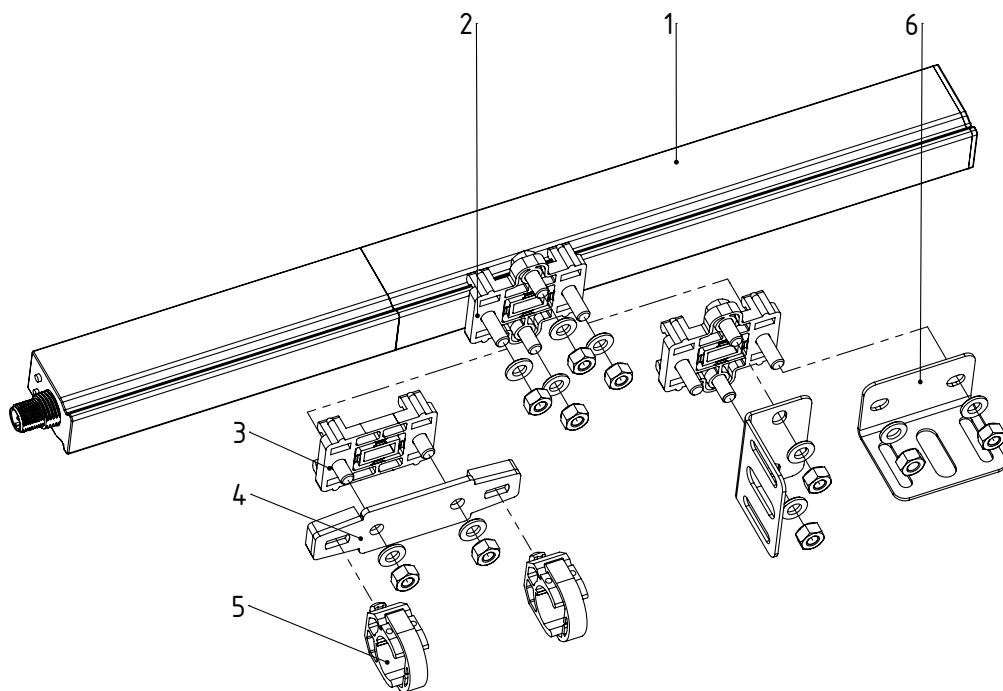

Fig. 4:
Assembling the
SDS discharging
bar

- | | |
|-------------------|------------------|
| 1 Discharging bar | 4 Adapter |
| 2 Bracket | 5 Clip |
| 3 Bracket small | 6 Mounting angle |

The profile of the bar features a through-going sideways groove in which the bar brackets are positioned at regular distances. The bar is fixed in place simply by tightening two bolts each for every bracket; torque: 0.8 Nm.



Caution!

Evenly space the brackets across the full length.
below 1 meter total length: 2 per bar
over 1 meter total length: 1 per meter
Only plastic assembly material may be used.

Z-118149y

An optional alternative is attaching the bars using a GRP round rod. Fig. 6 shows an assembly example. The bar is attached to the GRP round rod via plastic holders. An additional angle permitting easy fastening of system profiles is available as an option, see Fig. 5.

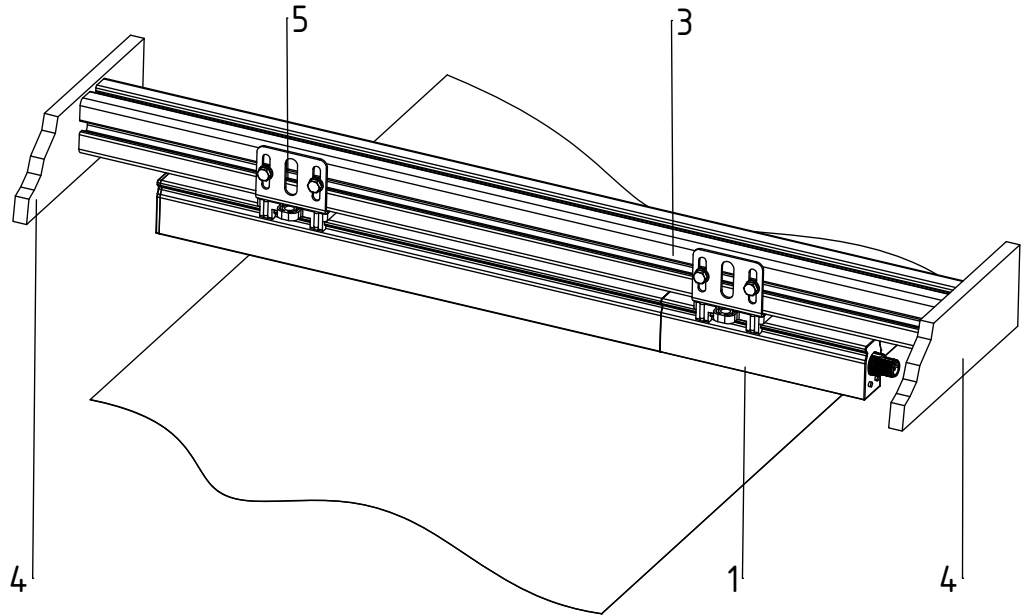

Fig. 5:
Assembly example
SDS with steel
brackets and alu-
minum profile

Z-118302y_1

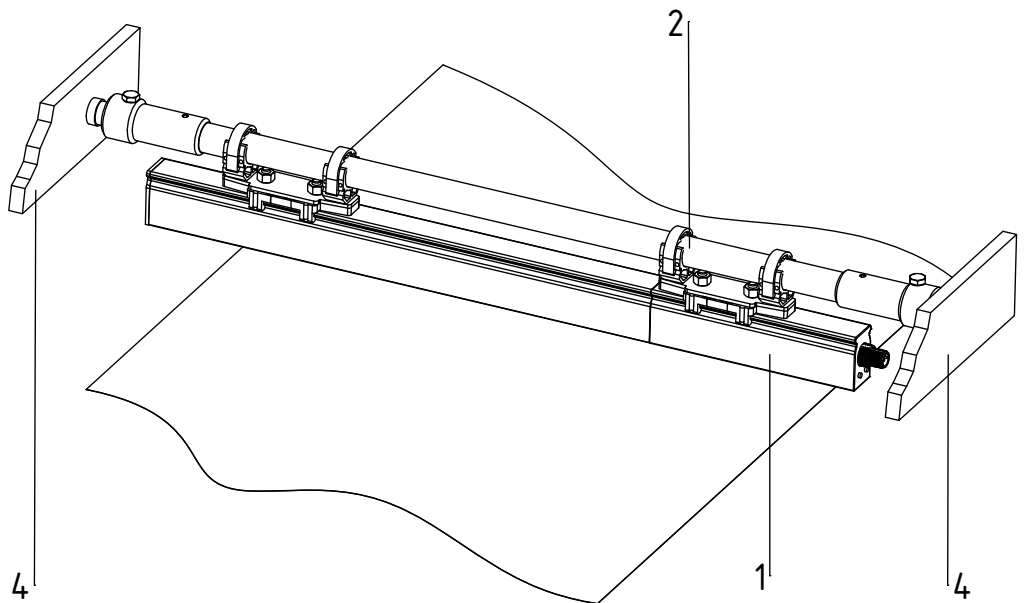

Fig. 6:
Assembly SDS
with GRP round
rod

Z-118302y_2

- | | |
|---------------------|------------------|
| 1 Discharging bar | 4 Machine wall |
| 2 GRP round rod | 5 Mounting angle |
| 3 Aluminium profile | |



Warning !

For safety in operation, please note the following:

- The bar must be mounted such that mechanical damage to the bar tips is ruled out.
- When routing the cable, select the attachment points such that mechanical damage to the cable (e.g. chafing against rotating machine parts) is ruled out.
- In applications involving moving bars, the cable must be attached such that there is no cable movement near the connection zone of the bar.
- Once the bars are installed, they must **always** be grounded regardless of the operating condition. Failure to take this into account will destroy the bar.

Locating the SDS discharging bar

The best possible discharging results are achieved when placing the bar in the operating range (see Chapter 2.5) in relation to the substrate to be discharged.



The discharging bar SDS must be positioned such that the distance between the emission tips and the object to be discharged is smaller than the distance to the grounded machine components; in simpler terms, this corresponds to a circle with a radius R around the emission tips; see Fig. 7.

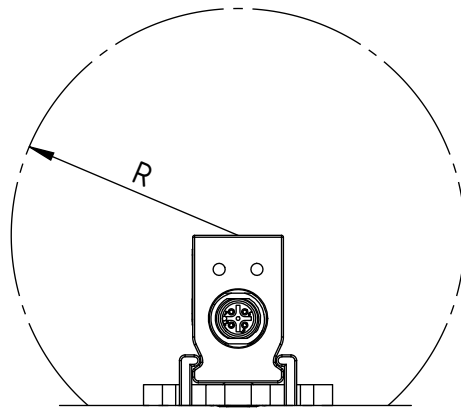

Fig. 7:
Zone free of conductive grounded material around the discharging bar

Distance frontal: min. 60mm!

Z-114897y_4

3.2 Connecting supply voltage

The operation of the discharging bar SDS requires a 24V DC supply designed for a maximum current of 0.5 A.

The supply voltage is to be supplied by the customer. Alternatively, the optional power supply units may be used (see chapter "Spare parts and Accessories". The connecting cable can be cut to size and prepared by the customer, or the ready cut and sized connecting cables available as accessories may be used.



To ensure that no voltage is supplied to the bars when the material web is at rest, enabling the supply voltage to the unit via machine contact is recommended. If the material web is at rest, or if the machine is not in operation, no high voltage is supplied to the bars in this case. When operating the bar using CANopen® it is advisable to block the enable function of the high voltage via the field bus while the machine is at standstill.



3.3 Ground connection

A shielded cable must be used when operating the bar. The shield must make close surface contact with ground potential at a suitable point. Make sure that the link between the shield and the ground potential is as low-resistance as possible.

Once the bars are installed, they must **always** be grounded regardless of the operating condition. Failure to take this into account will destroy the bar.

3.4 Plug connection

The bar is connected via a standard M12 A-coded round plug connector with 5 pins.

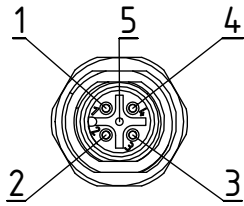

Fig. 8:
Connector
SDS discharging
bar

Z-114897y<-5

The supply voltage of 24 V DC has to be connected to the supply connector at contact 2 (24 V) and contact 3 (0 V).

Variant with fault signal output

Contact 5: Cable shield placed

Contact 4: connected to 0 V

Contact 1: 24 V signal to display the function of the bar

- Fault signal output Contact 1: 0 V
Bar not ready or error detected; high voltage is disabled.
- Fault signal output Contact 1: 24 V
Bar in operation

| Pin | Function |
|-----|------------------------|
| 1 | fault signal output |
| 2 | 24 V DC supply voltage |
| 3 | 0 V |
| 4 | 0 V |
| 5 | shield |

Variant with CANopen®

Contact 1: Cable shield placed

Contact 4: Bus signal CAN_H

Contact 5: Bus signal CAN_L

The pin assignment corresponds to the assignment of the M12 round plug connector for CANopen® specified in CiA 303-1.

| Pin | Function |
|-----|------------------------|
| 1 | shield |
| 2 | 24 V DC supply voltage |
| 3 | 0 V |
| 4 | CAN High |
| 5 | CAN Low |

See Chapter 8 Technical specifications for more electrical details on the various signals or supply voltages.

See Chapter 10 Spare parts and accessories for cables cut to size and prepared for connecting the bar for the different variants.



Caution!

When connecting the plug, make sure that the contacts are connected with the correct signals and the correct polarity of the supply voltage. Incorrect connection may irretrievably damage the bar.



Caution!

When using the variant with CANopen®, a cable with a surge resistance of 120 Ohm suitable for CAN bus networks must be used for both bus leads; this is the only way the proper function of the CAN network can be assured.

The maximum cable lengths specified in CiA 303-1 as factor of the transmission speed must be observed for the whole network and for the individual spur lines.

3.5 Use of the Eltex signal cable KS

When using the optional Eltex signal cable KS, the following colour markings should be observed when connecting the individual leads in the variants with open end Type KS/P, KS/Q, KS/R, KS/S, KS/V and KS/W.

Signal cable Type KS/P, KS/Q, KS/V and KSW

The signal cable variants KS/P, KS/Q, KS/V and KS/W are used for the bar variants SDS/xS with fault signal output and show the following usual colour markings of the individual cores:

| Core colour | Signal |
|-------------|------------------------|
| white | fault signal output |
| brown | 24 V DC supply voltage |
| green | 0 V |
| yellow | 0 V |
| shield | ground potential |

Signal cable Type KS/R und KS/S

The two signal cable variants KS/R and KS/S are used for connecting the bar variant SDS/xC with CANopen® and show the usual colour markings of the individual cores for CANopen® bus leads:

| Core colour | Signal |
|-------------|------------------------|
| red | 24 V DC supply voltage |
| black | 0 V |
| white | CAN High |
| blue | CAN Low |
| shield | ground potential |

When installing the signal cable, observe the following minimum bending radii.

| Kabel | KS/P, KS/R | KS/R, KS/S, KS/T, KS/U | KS/V, KS/W |
|--------|------------|------------------------|------------|
| fixed | 37,5 mm | 55,0 mm | 25 mm |
| moving | 95,0 mm | 110,0 mm | 50,0 mm |

3.6 CANopen® field bus interface

The discharging bars of the variant SDS/xC support the standardized CANopen® protocol according to CiA 301. The bar logs onto the network as a slave with the device profile 401 for input/output devices. The following CANopen® services are supported:

- Emergency Protokoll (EMCY) for the transmission of error and warning events
- Heartbeat Producer for node monitoring
- Static mapping for PDO transfer
All important data are available in PDOs verfügbar.
- Prompt SDO transfer
Segmented transfers and block transfers are not supported.
- CANopen® objects for storing und restoring parameter data
- LSS services for setting the node address and baud rate (see chapters 4.4 and 4.5).

The complete description of the CANopen® protocol for the SDS/xC discharging bar and the corresponding EDS file "SDS.eds" are available in are in separate files. The files are available for download on the product page Discharging/Discharging bars/SMART DISCHARGING SYSTEM SDS at www.eltex.de.

4. Operation



The discharging bars must be operated with a 24 V DC power supply.

4.1 Startup



Once all the connections have been correctly made, the system is operational and the supply voltage can be switched on.

4.2 Function monitoring

The proper function of the unit is signaled via the LEDs in the connection zone.

- **Fault signal output:** Display of the function
- **Variant with CANopen®:** Messages are not transmitted directly via the bus, but with the "Error Message" for CANopen® devices
- **Status-LED** (to the right of the plug):
Display of the different operating states

| Status-LED | State |
|--------------------|------------------------------|
| Red steady light | Initializing |
| Red flashing | Fault |
| Red 1 x flashing | System fault |
| Green steady light | High voltage ON |
| Green flashing | Warning and High voltage ON |
| Green 1 x flashing | Bar in standby mode |
| Green 2 x flashing | Warning and High voltage OFF |

- **CANopen®-Status-LED** (to the left of the plug):
Presentation of the LED outputs for the CAN bus specified under CiA 303-3

| CANopen® Status-LED | State |
|---|--|
| LED off | CANopen® not initialized |
| Green steady light | CANopen® Device in OPERATIONAL state |
| Green 1 x flashing | CANopen® device in STOPPED state |
| Green slowly flashing (2,5 Hz) | CANopen® device in PREOPERATIONAL state |
| Red / Green flashing alternately (10 Hz) | Automatic baud rate recognition or LSS Service in progress |
| Red steady light | CAN Controller is disabled |
| Red 1 x flashing | Transmission of too many error frames via the CAN bus |
| Red 2 x flashing | CANopen® fault monitoring event |
| Red 3 x flashing | CANopen® Sync error |
| Red / Green flashing alternately (different, changing flashing durations) | CANopen® communication error, restart of the bar is necessary. |

- If a warning message appears, the output of the high voltage will not be disrupted. There will be an internal switch-over of the bar with a controlled output of the high voltage. The adaptation of the high voltage to external conditions for optimizing discharging is inactive.
- If a fault occurs, the high voltage will be disabled at once and the fault signal output is pulled to 0 V.

Note!

Malfunctions are not saved. The disruption of the supply voltage automatically cancels the malfunction message. The fault or malfunction can be acknowledged via the field bus in the CANopen® variant.

4.3 Function control

Use the Eltex Volt Stick or a glow-lamp voltage tester to check the proper function of the emission points. Quote Article No. 109136 when ordering the Volt Stick from Eltex.

4.4 Setting the node address

The bars of the variant SDS/xC are delivered with the default node address 99 for the CANopen® network. The address can be changed with the "Layer Setting Services (LSS)" of the CANopen® standard; please refer to the CANopen® specification CiA 305. The node can be assigned any free address between 1 and 127 in the CANopen® network.

First switch the node to LSS status using the LSS services. Then change the node address with the "Configure Node-ID" service. Save the new address with the "Store Configuration" service of the LSS protocol. Finally switch the node back to LSS standby.

After a restart of communication / reset of the node using the NMT service, the discharging bar is available in the network with its new node address.

4.5 Changing the CAN baud rate

The SDS/xC bar is delivered with a default baud rate of 125 kBit/s (table index 4). In order to integrate the bar into the existing CANopen® network, you can adjust the baud rate via the LSS service of the CANopen® specification. Only the standard CiA table for bit timing is supported.

The SDS/xC bar supports the following baud rates:

| Baud rates | Table Index |
|-------------|-------------|
| 1000 kBit/s | 0 |
| 800 kBit/s | 1 |
| 500 kBit/s | 2 |
| 250 kBit/s | 3 |
| 125 kBit/s | 4 |
| 50 kBit/s | 6 |
| 25 kBit/s | 7 |
| 10 kBit/s | 8 |



Caution!

When integrating the SDS/xC bar into the network, it is important to ensure that all nodes in the CANopen® network are operated with the same baud rate, otherwise there may be communication errors at individual devices or, at worst, the entire network may crash.

First switch the node to LSS status using the LSS services. Then change the baud rate with the LSS service by configuring the bit timing. Save the new baud rate with the LSS service using "Store Configuration". The new baud rate is activated via "Activate Bit Timing Parameters". Be sure to select the waiting times so that all connected devices have enough time to switch to the new baud rate. Finally, switch the node back to LSS standby

4.6 Releasing the high voltage

For SDS/xS bars in perfect working condition, the high voltage used to discharge the substrate is released immediately after the 24 V DC supply voltage is switched on.

The bars with integrated CANopen® field bus (SDS/xC) are in standby mode after the start. The high voltage is deactivated and the bar waits for the high voltage to be released. Once the release signal has been transmitted, the bar changes its status and activates the high voltage for discharging.

The bar has an integrated timeout function for the release. This means that the release signal must be transmitted at regular intervals. If the release signal is not transmitted again via the field bus within 10 seconds, the high voltage is automatically deactivated. For a detailed description of the high voltage release via the CANopen® field bus, see the CANopen® protocol description of the SDS bar.

4.7 Clearing errors and warnings

For the bars with fault signal output (variant SDS/xS), errors and warnings can only be cleared by deactivating and reactivating the high voltage.

The bar variants with integrated field bus support the clearing of errors and warnings with a message that is transmitted via the bus. The error/warning message that is selected based on the transmitted code is then subjected to an internal check and cleared. Please note that not all error messages can be cleared via CANopen®. If an attempt is made to clear such an error message, the system issues a warning stating that the error message cannot be cleared. Error messages that cannot be cleared can only be eliminated by resetting the node using an NMT command or by deactivating and then reactivating the supply voltage. For more information, see the CANopen® protocol description of the SDS bar; the error and warning messages are listed in chapters 6.1 and 6.2.

5. Maintenance



Warning!

Electric shock hazard!

- Do not carry out any maintenance or repair work without first disconnecting the supply voltage of the units.
- The machine which has the units fitted must not be in operation.
- The bars passively absorb energy from the moving substrate web. The high voltage cable must be plugged in or grounded to the power supply. If the high voltage cable is disconnected, the plug is live (high voltage) and applies with full power on the plug; this may cause a spark discharge and may lead to a risk of injury. Disconnected high voltage plugs are not permitted or have to be grounded.
- Repairs and maintenance work must be carried out by qualified personnel only.

To ensure the trouble-free function of the discharging bars, clean the bars regularly depending on pollution with compressed air free of oil and water (max. 6×10^5 Pa and standard compressed air pistol) and a brush with soft plastic bristles (see [chapter 9 "Spare parts and accessories"](#), [page 43](#)).

Clean grease, ink, glue, paper dust, etc. off the discharging bar and the distance detection using a suitable solvent (benzine). Do not soak the bars and the high voltage cable in solvent!



Caution!

Do not damage the emission tips when cleaning. Brush only in longitudinal direction.



Warning!

Risk of deflagration!

Allow the solvent to evaporate completely before restarting the discharging bar.

Inspection of the protective resistors - contact protection

The function and the appearance of the protective resistors must be inspected at regular intervals. The inspection intervals are specified in the accident prevention regulations, as amended (e.g. in Germany DGUV V3).

When inspecting the protective resistance of the individual ionization tips, the first tips seen from the connector (variant SDS/N = 4 tips, SDS/E = 3 tips) are decoupled via a common resistor; this means that only one tip of the jointly decoupled tips to the remaining tips can be inspected.

The function of the series resistors between two ionization tips of the same polarity must be checked using a suitable measuring device. The test voltage must be 1,000V. The measured resistance between the first combined decoupled tips and the single decoupled tips must not fall below 294 MOhm and not exceed 386 MOhm. The resistance between the single decoupled tips must not fall below 192 MOhm and not exceed 288 MOhm.

6. Troubleshooting



Warning!

Electric shock hazard!

- Do not carry out any maintenance or repair work without first disconnecting the supply voltage.
- The machine which has the units fitted must not be in operation.
- Repairs and maintenance work must be carried out by qualified personnel only.

| Malfunction | Cause | Measure |
|------------------|---|---|
| red LED flashing | <ul style="list-style-type: none"> • Dirty bar. • Sparking against metallic machine parts. • Serious source of EMC interference in the vicinity of bar or power supply units | <ul style="list-style-type: none"> • Clean bar (see chapter Maintenance). • Check installation situation. • Locate and rectify the source of interference, if necessary take measures to suppress interference |
| red LED on | <ul style="list-style-type: none"> • Internal error. | <ul style="list-style-type: none"> • Acknowledge the malfunction; disconnect the supply voltage and restart the unit. • If the malfunction recurs, send the unit for repair. |
| No LED on | <ul style="list-style-type: none"> • Supply voltage not enabled or not connected. • Defective internal fuse. • Defective LED. | <ul style="list-style-type: none"> • Check supply voltage, connections and connected cables. • Acknowledge the malfunction; disconnect the supply voltage and restart the unit. • If the malfunction recurs, send the unit for repair. |

6.1 Error messages

The EMCY service of the SDS/xC bar (CANopen® -capable) provides additional information on the cause of the error. The data value 0x01 of the first byte in the manufacturer-specific part indicates an error message. The second byte contains the error number. The table below shows a list of the error numbers. More details are available in the CANopen® protocol description of the SDS bar.

| Error number | Error clearable | Cause | Measure |
|--------------|-----------------|---------------------------------|--|
| 1 | No | Initialization failed | <ul style="list-style-type: none"> Interrupt the supply voltage. If this error occurs again, send in the device for repairs. |
| 2 | No | CPU clock faulty | <ul style="list-style-type: none"> Interrupt the supply voltage. If this error occurs again, send in the device for repairs. |
| 4 | No | Invalid interface configuration | <ul style="list-style-type: none"> Interrupt the supply voltage. If this error occurs again, send in the device for repairs. |
| 5 | No | Invalid error number | <ul style="list-style-type: none"> Interrupt the supply voltage. If this error occurs again, send in the device for repairs. |
| 6 | No | Invalid error status | <ul style="list-style-type: none"> Interrupt the supply voltage. If this error occurs again, send in the device for repairs. |
| 7 | No | Invalid warning number | <ul style="list-style-type: none"> Interrupt the supply voltage. If this error occurs again, send in the device for repairs. |
| 8 | No | Invalid warning status | <ul style="list-style-type: none"> Interrupt the supply voltage. If this error occurs again, send in the device for repairs. |

| Error number | Error clearable | Cause | Measure |
|---------------------|------------------------|-----------------------------------|--|
| 9 | No | Invalid lock of the output stages | <ul style="list-style-type: none"> • Interrupt the supply voltage. • If this error occurs again, send in the device for repairs. |
| 10 | No | Invalid system status | <ul style="list-style-type: none"> • Interrupt the supply voltage. • If this error occurs again, send in the device for repairs. |
| 11 | No | Invalid calibration data | <ul style="list-style-type: none"> • Interrupt the supply voltage. • If this error occurs again, send in the device for repairs. |
| 14 | No | Invalid parameter data | <ul style="list-style-type: none"> • Interrupt the supply voltage. • If this error occurs again, send in the device for repairs. |
| 15 | No | Invalid operating status | <ul style="list-style-type: none"> • Interrupt the supply voltage. • If this error occurs again, send in the device for repairs. |
| 16 | No | Invalid command parameter access | <ul style="list-style-type: none"> • Interrupt the supply voltage. • If this error occurs again, send in the device for repairs. |
| 17 | No | Invalid application status | <ul style="list-style-type: none"> • Interrupt the supply voltage. • If this error occurs again, send in the device for repairs. |
| 18 | No | Invalid data block | <ul style="list-style-type: none"> • Interrupt the supply voltage. • If this error occurs again, send in the device for repairs. |
| 19 | No | Invalid data position | <ul style="list-style-type: none"> • Interrupt the supply voltage. • If this error occurs again, send in the device for repairs. |

| Error number | Error clearable | Cause | Measure |
|---------------------|------------------------|--|---|
| 20 | No | Internal 3.3 V supply faulty | <ul style="list-style-type: none"> • Check the 24 V DC supply. • Interrupt the supply voltage. • If this error occurs again, send in the device for repairs. |
| 21 | No | Internal 5 V supply faulty | <ul style="list-style-type: none"> • Check the 24 V DC supply. • Interrupt the supply voltage. • If this error occurs again, send in the device for repairs. |
| 22 | Yes | 24 V DC supply faulty | <ul style="list-style-type: none"> • Check the 24 V DC supply. • Interrupt the supply voltage. • If this error occurs again, send in the device for repairs. |
| 25 | Yes | Positive high voltage faulty | <ul style="list-style-type: none"> • Clean the bar. • Check the mounting position. • Clear the error. • If this error occurs again, send in the device for repairs. |
| 26 | Yes | Negative high voltage faulty | <ul style="list-style-type: none"> • Clean the bar. • Check the mounting position. • Clear the error. • If this error occurs again, send in the device for repairs. |
| 27 | Yes | Deviation: positive high voltage to setpoint is too high | <ul style="list-style-type: none"> • Clean the bar. • Check the mounting position. • Clear the error. • If this error occurs again, send in the device for repairs. |

| Error number | Error clearable | Cause | Measure |
|---------------------|------------------------|--|---|
| 28 | Yes | Deviation: negative high voltage to setpoint is too high | <ul style="list-style-type: none"> • Clean the bar. • Check the mounting position. • Clear the error. • If this error occurs again, send in the device for repairs. |
| 30 | Yes | Current: Positive high voltage is too high | <ul style="list-style-type: none"> • Clean the bar. • Check the mounting position. • Clear the error. • If this error occurs again, send in the device for repairs. |
| 31 | Yes | Current: Negative high voltage is too high | <ul style="list-style-type: none"> • Clean the bar. • Check the mounting position. • Clear the error. • If this error occurs again, send in the device for repairs. |
| 33 | Yes | Power maximum: positive high voltage exceeded | <ul style="list-style-type: none"> • Clean the bar. • Check the mounting position. • Clear the error. • If this error occurs again, send in the device for repairs. |
| 34 | Yes | Power maximum: negative high voltage exceeded | <ul style="list-style-type: none"> • Clean the bar. • Check the mounting position. • Clear the error. • If this error occurs again, send in the device for repairs. |
| 35 | Yes | Lock of the high voltage has failed | <ul style="list-style-type: none"> • Interrupt the supply voltage. • If this error occurs again, send in the device for repairs. |
| 36 | Yes | Setpoint setting has failed | <ul style="list-style-type: none"> • Interrupt the supply voltage. • If this error occurs again, send in the device for repairs. |

| Error number | Error clearable | Cause | Measure |
|---------------------|------------------------|---|---|
| 37 | Yes | Invalid release status | <ul style="list-style-type: none"> • Interrupt the supply voltage. • If this error occurs again, send in the device for repairs. |
| 39 | Yes | Pollution maximum exceeded | <ul style="list-style-type: none"> • Clean the bar. • Check the mounting position. • Clear the error. • If this error occurs again, send in the device for repairs. |
| 42 | Yes | General memory error | <ul style="list-style-type: none"> • Clear the error. • If this error occurs again, send in the device for repairs. |
| 43 | Yes | Memory read access | <ul style="list-style-type: none"> • Clear the error. • If this error occurs again, send in the device for repairs. |
| 44 | Yes | Memory write access | <ul style="list-style-type: none"> • Clear the error. • If this error occurs again, send in the device for repairs. |
| 45 | Yes | Invalid parameter address | <ul style="list-style-type: none"> • Interrupt the supply voltage. • If this error occurs again, send in the device for repairs. |
| 46 | Yes | Positive passive leakage current too high | <ul style="list-style-type: none"> • Clean the bar. • Check the mounting position. • Clear the error. • If this error occurs again, send in the device for repairs. |
| 47 | Yes | Negative passive leakage current too high | <ul style="list-style-type: none"> • Clean the bar. • Check the mounting position. • Clear the error. • If this error occurs again, send in the device for repairs. |

| Error number | Error clearable | Cause | Measure |
|---------------------|------------------------|--|--|
| 48 | Yes | Fault signal output | <ul style="list-style-type: none"> • Clear the error. • If this error occurs again, send in the device for repairs. |
| 49 | Yes | LEDs | <ul style="list-style-type: none"> • Clear the error. • If this error occurs again, send in the device for repairs. |
| 64 | Yes | CAN communication | <ul style="list-style-type: none"> • Check bus cabling. • Check baud rate. • Clear the error. • If this error occurs again, send in the device for repairs. |
| 65 | Yes | General CANopen® - communication error | <ul style="list-style-type: none"> • Check bus cabling. • Check CANopen® - transmission. • Clear the error. • If this error occurs again, send in the device for repairs. |
| 66 | Yes | CANopen® - SDO access | <ul style="list-style-type: none"> • Check SDO transmission protocol. • Clear the error. • If this error occurs again, send in the device for repairs. |
| 67 | Yes | CANopen® - PDO access | <ul style="list-style-type: none"> • Check PDO transmission protocol. • Compare PDO access with the EDS file. • Clear the error. • If this error occurs again, send in the device for repairs. |

| Error number | Error clearable | Cause | Measure |
|---------------------|------------------------|---|---|
| 68 | Yes | CANopen® - PDO data length is faulty | <ul style="list-style-type: none"> • Check PDO transmission protocol. • Clear the error. • If this error occurs again, send in the device for repairs. |
| 69 | Yes | CANopen® buffer overflow | <ul style="list-style-type: none"> • Bus load is too high. • Too many CAN messages have been sent. • Clear the error. • If this error occurs again, send in the device for repairs. |
| 70 | Yes | CANopen® error field transmission error | <ul style="list-style-type: none"> • Clear the error. • If this error occurs again, send in the device for repairs. |
| 71 | Yes | CANopen® node monitoring | <ul style="list-style-type: none"> • Check node monitoring of the CANopen® master. • Clear the error. • If this error occurs again, send in the device for repairs. |
| 72 | Yes | Error during re-establishment of connection | <ul style="list-style-type: none"> • Check bus cabling. • Check baud rate. • Clear the error. • If this error occurs again, send in the device for repairs. |

6.2 Warning messages

The EMCY service of the SDS/xC bar (CANopen®-capable) provides additional information about the cause of the warning. The data value 0x05 of the first byte in the manufacturer-specific part indicates a warning message. The second byte contains the warning number. The table below shows a list of the warning numbers. More details are available in the CANopen® protocol description of the SDS bar..

| Warning number | Cause | Measure |
|----------------|--|---|
| 1 | Error cannot be cleared. | <ul style="list-style-type: none"> Interrupt the supply voltage. If this error occurs again, send in the device for repairs. |
| 2 | Clearable error has not occurred. | <ul style="list-style-type: none"> Clear the warning. |
| 3 | The error counter shows an invalid reading. | <ul style="list-style-type: none"> Clear the warning. |
| 4 | The release of the output stage has been disabled. | <ul style="list-style-type: none"> An error occurred during the release of the high voltage. Do not send the release telegram again. First eliminate the cause of the error, then clear the warning. |
| 18 | Positive creeping current is too high. | <ul style="list-style-type: none"> Clean the bar. Check the mounting position. Clear the warning. |
| 19 | Negative creeping current is too high. | <ul style="list-style-type: none"> Clean the bar. Check the mounting position. Clear the warning. |
| 20 | Positive passive leakage current above warning level | <ul style="list-style-type: none"> Clean the bar. Check the mounting position. Clear the warning. |
| 21 | Negative passive leakage current above warning level | <ul style="list-style-type: none"> Clean the bar. Check the mounting position. Clear the warning. |
| 22 | Pollution above warning level | <ul style="list-style-type: none"> Clean the bar. Check the mounting position. Clear the warning. |

| Warning number | Cause | Measure |
|-----------------------|--------------------------------|--|
| 81 | Parameter value below minimum. | <ul style="list-style-type: none"> • Parameter was automatically corrected to minimum. • Clear the warning. |
| 82 | Parameter value above maximum. | <ul style="list-style-type: none"> • Parameter was automatically corrected to maximum. • Clear the warning. |
| 84 | Invalid parameter value | <ul style="list-style-type: none"> • Parameter was not changed. Transmit correct value. • Clear the warning. |

7. Technical specifications SDS

| Input | |
|-------------------------------|---|
| Supply voltage | 24 V DC $\pm 10\%$ |
| Current input | max. 0.5 A |
| Power input | max. 12 W |
| Recommended protection | 2A Tripping characteristic C |
| Connectivity | |
| Interfaces | CANopen® |
| Output | |
| Output voltage | SDS/N: ± 7 kV SDS/E: ± 11 kV |
| Short-circuit current/tip | SDS/N: max. 0.075 mA SDS/E: max. 0.120 mA |
| Frequency | 30 - 50 Hz adjustable, via CANopen® Default values: SDS/N: 48 Hz SDS/E: 40 Hz |
| Features | |
| Ionenbalance | preset setting |
| Fuse monitoring | fixed protection circuit |
| Pollution monitoring | existing |
| Key data | |
| Bar element | glass-fiber reinforced plastic GRP |
| Encapsulation material | polyurethane |
| Emission tips | tungsten |
| Installation material | glass-fiber reinforced plastic holder, plastic screw M6 (washer and nut) included in the delivery |
| Operating ambient temperature | +5...+50 °C (+41...+122 °F) |
| Ambient humidity | max. 80 % RH, non-dewing |
| Storage temperature | -20...+80 °C (-4...+176 °F) |

| Key data | |
|---|--|
| Protection class Housing / Round plug connector | IP66 according to EN 60529 |
| Contact protection | according to EN 61140 |
| Available active lengths | SDS/N: 330 - 3990 mm in 60 mm steps SDS/E: 315 - 3915 mm in 90 mm steps |
| Operating distance | SDS/N: min 100 - 150 mm SDS/E: min. 150 - 300 mm |
| Fault signal output | 24 V DC $\pm 10\%$, max. 0,05 A (internal fuse) |
| Round plug connector | M12x1 A-coded connector with 5 pins |
| Dimensions (without bracket) | SDS/N: 24 mm x 39 mm x total length max. length 4060 mm SDS/E: 24 mm x 39 mm x total length max. length 4015 mm |
| Weight | approx. 1.3 kg/m |
| Supported CANopen® baud rates | 10 kBit/s, 20 kBit/s, 50 kBit/s, 125 kBit/s, 250 kBit/s, 500 kBit/s, 800 kBit/s, 1000 kBit/s |



8. Dimensions

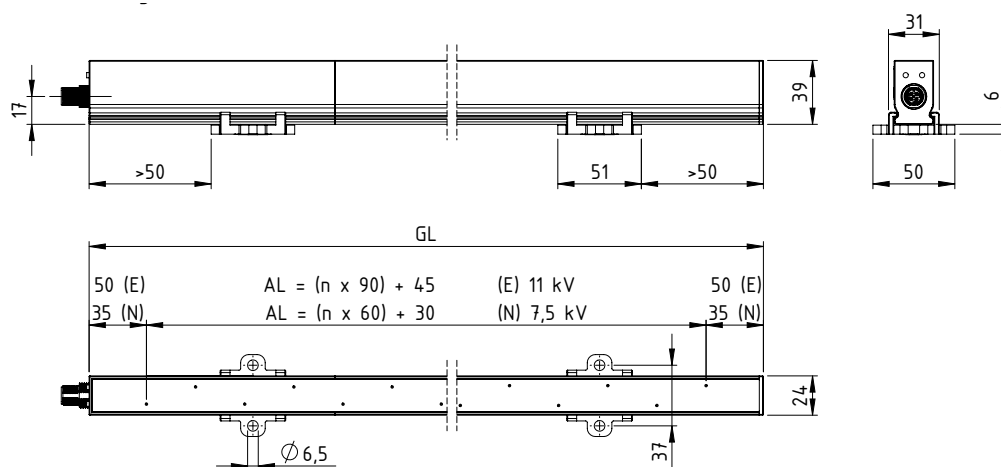

Fig. 9:
SDS
discharging bar

AL = active length N = close range
E = enlarged range

Z-114897y_2

Available lengths of the SDS bar

| reference code | active length | grid pattern |
|----------------|------------------|--------------|
| SDS/N | 330 mm - 3990 mm | 60 mm |
| SDS/E | 315 mm - 3915 mm | 90 mm |

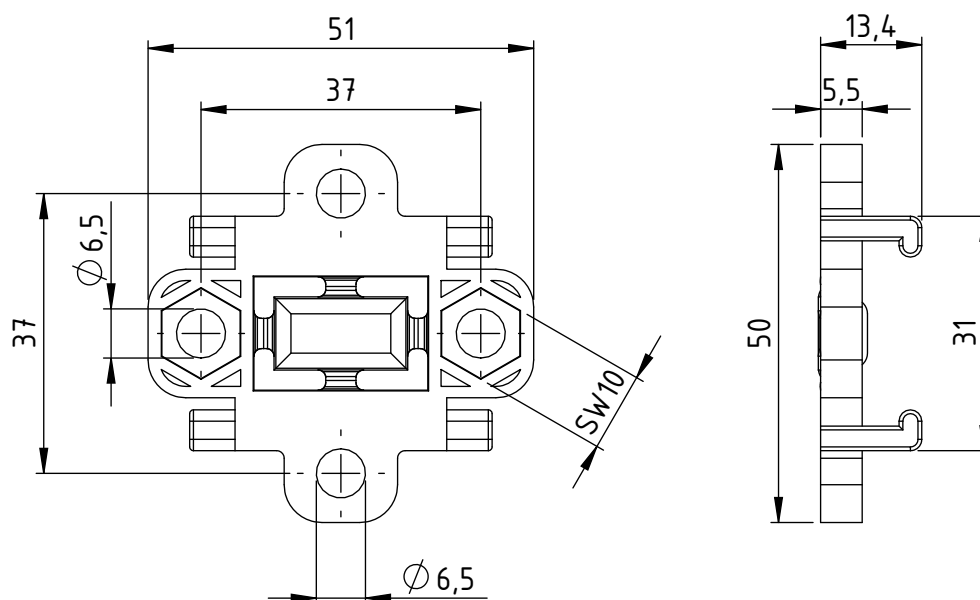
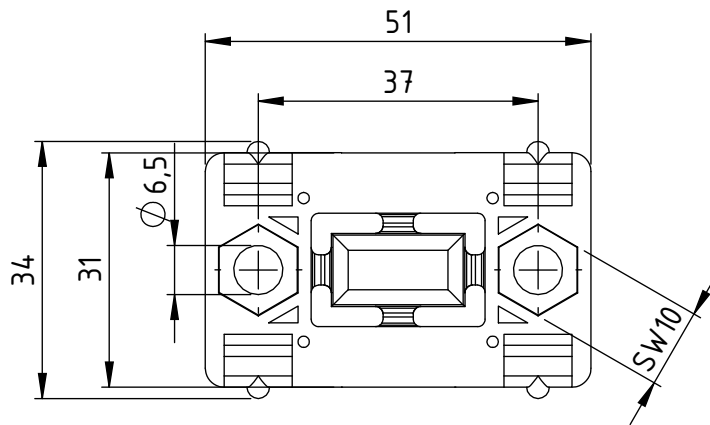

Fig. 10:
Holder standard

Z-114897y_3

Fig. 11:
Holder small



Z-114897ay_6

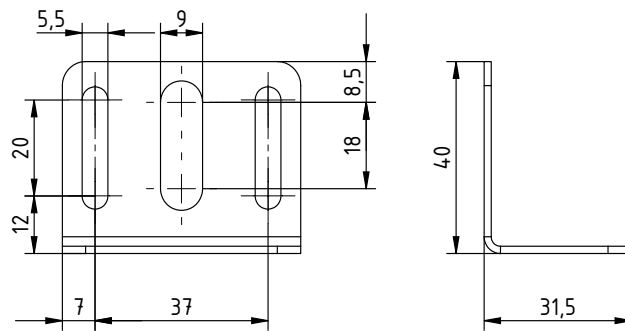
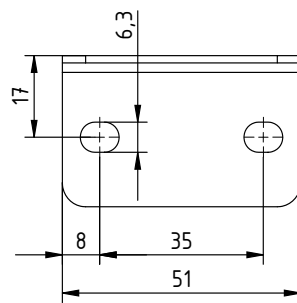

Fig. 12:
Holding angle



Z-115665ay_6

9. Spare parts and accessories

| Article | Article No. |
|--|-------------|
| Cable SDS/xS S = bar with fault signal output P = straight socket / open end (specify cable length) | KS/P |
| Cable SDS/xS S = bar with fault signal output Q = angled socket / open end (specify cable length) | KS/Q |
| Cable SDS/xS S = bar with fault signal output V = straight socket / open end suitable for carrier chain (specify cable length) | KS/V |
| Cable SDS/xS S = bar with fault signal output W = angled socket / open end suitable for carrier chain (specify cable length) | KS/W |
| Cable SDS/xC C = bar with CANopen® R = straight socket / open end suitable for carrier chain (specify cable length) | KS/R |
| Cable SDS/xC C = bar with CANopen® S = angled socket / open end suitable for carrier chain (specify cable length) | KS/S |
| Cable SDS/xC C = bar with CANopen® T = straight socket / straight plug suitable for carrier chain (specify cable length) | KS/T |
| Cable SDS/xC C = bar with CANopen® U = angled socket / straight plug (specify cable length) | KS/U |

| Article | Article No. |
|---|-------------|
| Installation material for SDS bars | |
| Installation set for SDS bars, standard | 114793 |
| Installation set for SDS bars, small | 114794 |
| Installation material for fixing GRP round rod Ø 20 mm | 115075 |
| Mounting angle cf. Fig. 5, Fig. 6 | 115465 |
| GRP round rod Ø 20 mm | HAGFK/_ _ |
| Bar holder for round rod | 101075 |
| Attachment clip for round rod | MCH02434 |
| Bar holder with clamps | HA01/_ _ _ |
| Bar holder with perforated plate | HA02/_ _ _ |
| T-distributor M12x5 | 114854 |
| Terminating plug CANopen® | 114855 |
| Terminating box CANopen® | 117550 |
| Adapter D-Sub socket, M12 plug | 114858 |
| Volt Stick | 109136 |
| Power supply DIN Rail 24 V DC 100 W 85 V AC - 264 V AC; 45 - 65 Hz | 115047 |
| Power supply DIN Rail 24 V DC 12 W, straight socket 85 V AC - 264 V AC; 47 - 63 Hz (for variants with fault signal output SDS/xS) | 115057 |
| Plug-in Power supply 24 V DC 12 W, angled socket 85 V AC - 264 V AC; 47 - 63 Hz (for variants with fault signal output SDS/xS) | 115360 |
| Cleaning brush with handle | RBR22 |
| Operating instructions (specify language) | BA-xx-2080 |

Please specify the article number when ordering.

EU-Declaration of Conformity

CE-2080-en-2402

Eltex-Elektrostatik Gesellschaft mbH
Blauenstraße 67-69

D-79576 Weil am Rhein

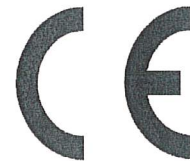

declares in its sole responsibility that the product

Smart Discharging System / Discharging Bar SDS (according to Eltex reference code)

complies with the following directives and standards.

Relevant EU-Directive:

2014/35/EU

Low Voltage Directive

Harmonized standard applied:

EN 60204-1:2018

Safety of machinery – Electrical equipment of machines –
General requirements

Relevant EU-Directive:

2014/30/EU

EMC Directive

Harmonized standards applied:

EN IEC 61000-6-2:2019

Electromagnetic compatibility (EMC) – Generic standards –
Immunity for industrial environments

EN 55011:2016 + A1:2017
+ A11:2020 + A2: 2021

Information technology equipment –
Radio-disturbance characteristics – Limits and methods
of measurement

Relevant EU-Directive:

2011/65/EU

RoHS Directive

in the version effective at the time of delivery.

Eltex-Elektrostatik Gesellschaft mbH keep the following documents for inspection:

- proper operating instructions
- plans
- other technical documentations

Weil am Rhein, 15.02.2024
Place/Date



Lukas Hahne, Managing Director

UKCA Declaration of Conformity

CA-2080-en-2402

Eltex-Elektrostatik-Gesellschaft mbH
Blauenstraße 67 - 69
D-79576 Weil am Rhein



declares in its sole responsibility that the product

Smart Discharging System / Discharging Bar SDS (according to Eltex reference code)

complies with the following directives and standards.

Applicable Regulation:

S.I. 2016 No. 1101

Electrical Equipment (Safety) Regulations

Used Designated Standard:

BS EN 60204-1:2018

Applicable Regulation:

S.I. 2016 No. 1091

Electromagnetic Compatibility Regulations

Used Designated Standard:

BS EN IEC 61000-6-2:2019

BS EN 55011:2016+A2:2021

Applicable Regulation:

S.I. 2012 No. 3032

RoHS Regulations

in the version effective at the time of delivery.

Eltex-Elektrostatik-Gesellschaft mbH keep the following documents for inspection:

- proper operating instructions
- plans
- other technical documentation

Weil am Rhein, 15.02.2024
Place/Date

Lukas Hahne, Managing Director

Eltex offices and agencies

The addresses of all
Eltex agencies can be
found on our website at
www.eltex.de



z01007y



Eltex-Elektrostatik-Gesellschaft mbH
Blauenstraße 67-69
79576 Weil am Rhein | Germany
Phone +49 (0) 7621 7905-422
eMail info@eltex.de
Internet www.eltex.de