

Operating Instructions

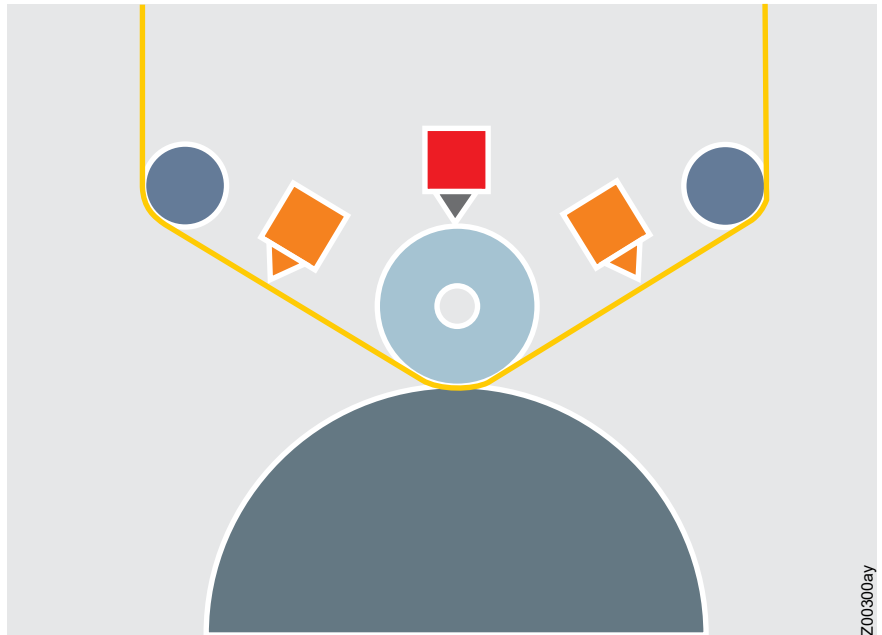

POWER TOP Electrostatic Printing Assist Series GNH63

BA-en-9070-2306



List of contents

1	System description	6
1.1	Function	6
1.2	Printing quality	8
1.3	System structure	9
1.4	System components	10
2	Safety	12
2.1	Identification of risks and hazards	12
2.2	Contact protection	12
2.3	Inspection of the protective resistors - contact protection	12
2.4	Technical advance	13
2.5	Proper use	13
2.6	Work and operational safety	13
3	Installation and assembly	19
3.1	Protective circuit, enable signals	19
3.2	Impression roller environment	22
3.3	Assembling the impression roller electrode	24
3.4	Installation site and spacings for the impression roller electrode	25
3.5	Design of the impression roller electrode	26
3.6	Assembling the discharging electrode #	28
3.7	Installation site and spacings for the discharging electrode #	30
3.8	High voltage generator	31
3.9	Visualization system Eltex Connected Control ECC #	31
3.10	Electrical connection	31
4	Operation	32
4.1	Startup	32
4.2	ESA operating mode	32
4.3	Setpoint setting	33
4.4	Operating the system directly via the generator POWER CHARGER PCTL	34
4.5	Operating the system via the visualization system Eltex Connected Control ECC #	34
4.5.1	Rapid start-up	35
4.5.2	Emergency operation without visualization system ECC	35
4.6	Operating the system via the control room integration	35
4.6.1	Functions and default settings, Charging parameters	36
4.6.2	Functions and default settings, Discharging parameters #	37
4.6.3	Functions and default settings, General parameters	38
4.6.4	Functions and default settings, Interface parameters	38

5	Maintenance	39
5.1	High voltage generator	39
5.2	Electrodes	39
5.3	Inspection of the protective resistors - contact protection	40
5.4	Visualization system Eltex Connected Control ECC #	41
6	Trouble-shooting	42
6.1	Error messages Visualization system Eltex Connected Control ECC #	42
6.2	Error messages Generator	42
7	Spare parts and accessories	44
A	Annex	46
A.1	Electrical property requirements of impression rollers when using Eltex GNH63 Printing Assists	46
A.2	Measurement regulations for 2-layer impression rollers for Eltex GNH63 Printing Assists	48
A.3	Measurement regulations for 3-layer impression rollers for Eltex GNH63 Printing Assists	49
A.4	Test certificate impression roller coating	51
A.5	Set-down regulations for impression rollers	52
A.6	Setting down impression rollers in packaging printing	53
A.7	Pollution monitoring	54
A.8	Installation according to NEC	55

8

#: The optional components or functions are marked with this symbol.

Dear customer,

The main function of the electrostatic printing assist ESA in gravure printing is to support the discharge of the ink-filled cells to avoid missing dots.

Also, the discharging performance of the cells is improved overall. This means that the printing density can be controlled to a certain extent.

The ESA system monitors the charge conditions in the printing units in which this system is installed.

The benefits:

- Improved printing quality (no missing dots)
- Less wear on the impression rollers by reducing the mechanical contact force
- Suitable for use in the EX zone in the gas categories IIA or IIB in all currently known solvents (details please see Technical specifications in the Operating Instructions of the used electrode such as:
 - water
 - ethyl acetate
 - ethanol
 - toluene
 - ethyl-water mixture

Please read these instructions carefully before starting the unit. This will help you prevent personal injuries and damage to property.

Simply give us a call if you have any suggestions, proposals or ideas for improvements. We greatly appreciate the feedback from the users of our appliances.

1. System description

1.1 Function

The electrostatic printing assist ESA utilises the physical fact that electrically charged particles (gravure inks are composed of such particles) are exposed to forces in an electrical field which always shift the particles into areas with higher field strengths.

A simple plate condenser (Fig. 1) will help to illustrate this situation.

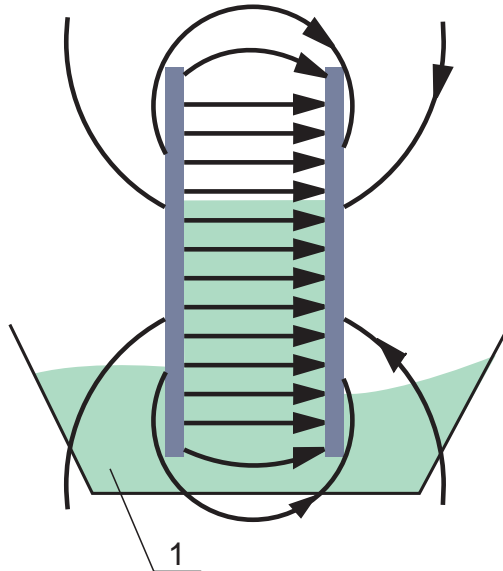

Fig. 1:
Plate condenser

1 dielectric
insulator

z00301y

When applying an electrical voltage, the plate condenser generates a homogeneous electrical field between the plates which has a much lower field strength at the edges and outside the plates than between the actual plates. If this plate condenser is immersed into a tub filled with gravure ink, the uncharged ink particles turn into dipoles and migrate against the forces of gravity into areas with higher field strengths.

The ink rises up between the plates until the weight force of the particles and the force exerted on the particles by the electrical field are in equilibrium.

If this mechanism is applied to an ink-filled cell (Fig. 2), the electrical field at the edge of the cell will cause the ink to migrate to areas with higher field strengths. The ink leaves the cells and will make the desired contact with the substrate to be printed, e.g. the gravure paper.

Fig. 2:
The function principle

- 1 Printing unit
- 2 Dielectric insulator
- 3 Impression roller
- 4 Paper
- 5 Printing cylinder
- 6 Filled cell

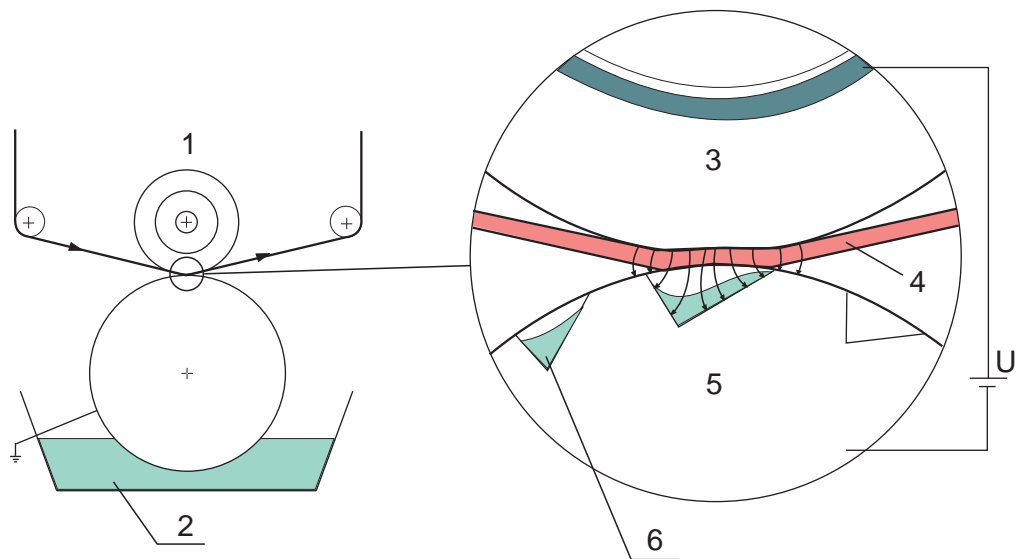

z000302y

In gravure printing the electrical field is generated in the printing nip between impression roller and impression cylinder. Both the substrate to be printed and the ink are dielectric materials, i.e. insulators.

To achieve the desired effect, electrical field strengths of between 3...5 megavolt per meter are required.

The electrical field strength is defined as follows:

$$\text{electrical field strength} = \text{voltage} / \text{distance}$$

With a distance of 0.1 mm, which is roughly the thickness of gravure paper, the voltage required is between 300 and 500 Volt.

This voltage is superimposed by another physical variable, i.e. the breakdown strength of the substrate to be printed. The type of material, its density and its moisture content determine the breakdown strength, which is also measured in volts.

The breakdown strength specifies the highest voltage obtainable in the printing nip and hence the highest possible field strength.

For this reason, voltages >500 Volt are not possible in the printing nip, because the breakdown strength of commonly used gravure paper is below this limit.

However, higher voltages are found in plastic foils and films.

In a system comprising a voltage source and an ideal condenser, a current will only flow if the energy state of the condenser changes, i.e. if it is charged or discharged.

Now, since ink continually rises into the electrical field when the cells discharge, and since non-polarised paper continually runs through the field space in the printing nip, this means that dielectric insulators are permanently fed into the electrical field. This also means that a low but consistent current has to flow to keep up the proper effect of the ESA system.

Other partial currents develop when:

- the breakdown strength of the substrate is exceeded,
- the impression roller makes direct contact with the impression cylinder.

This is why these partial currents dominate the total current and need to be limited by the system to a magnitude which prevents local heat development of the impression roller surface and sparking (explosion hazard area, because flammable solvents are often used in gravure printing).

1.2 Printing quality

The proper function of the electrostatic printing assist depends on a number of different conditions which must be met if printing without missing dots is to be assured.

- The system must always be kept clean and in proper working order. This applies, in particular, to the impression roller and the electrodes.
- The impression roller coating must comply with the surface and insulation resistance values specified in the Eltex Impression Roller Specifications (see Annex). These values are crucial under operating conditions. The impression roller coater must therefore re-calculate any changes in the materials he uses by taking the following factors into account.
 - homogeneity of the coating over the entire width of the impression roller, max. deviation from the mean value 20%.
 - the changes in resistance values in the insulation and the semiconductor layer caused by normal machine warm-up, feeding high voltage into the layers, temperature increase caused by mechanical contact pressure in the printing nip.
- All dimensional measurements of the impression roller coatings must be carried out on clean surfaces. Cleaning must be carried out using solvents to remove inks and fibre dust, and with water to remove deposits caused by printing on surface-coated papers.
- The material to be printed (paper or film) must have a volume resistance of $>10^{10} \Omega$. Besides the proportion of solids, the volume resistance of the paper is decisively affected by the water content. Eltex recommend a water content for gravure paper within the range from 4...4.5%.

- Recycled materials and some films have a lower volume resistance and higher roughness depths. Before using materials of this description, first check these for the printability with the ESA printing assist.
- Ink conductivity must be below 100 $\mu\text{S}/\text{cm}$. Conductive inks such as metallic inks carry a higher risk of fire in the explosion hazard area and must not be used together with the ESA.
- The proper drying of the ink is also important. Inadequately dried inks in connection with double-sided printing and with the nip voltage of the printing assist can cause smudging on the impression roller surface of the second print run. This would cause a loss in quality in the second print in the shape of clouding or stripes.

1.3 System structure

These operating instructions describe the maximum configuration of the system. Depending on design, not all components or functions may be available in your version. The optional components or functions are marked with the following symbol: #

The individual components are described on the next page.

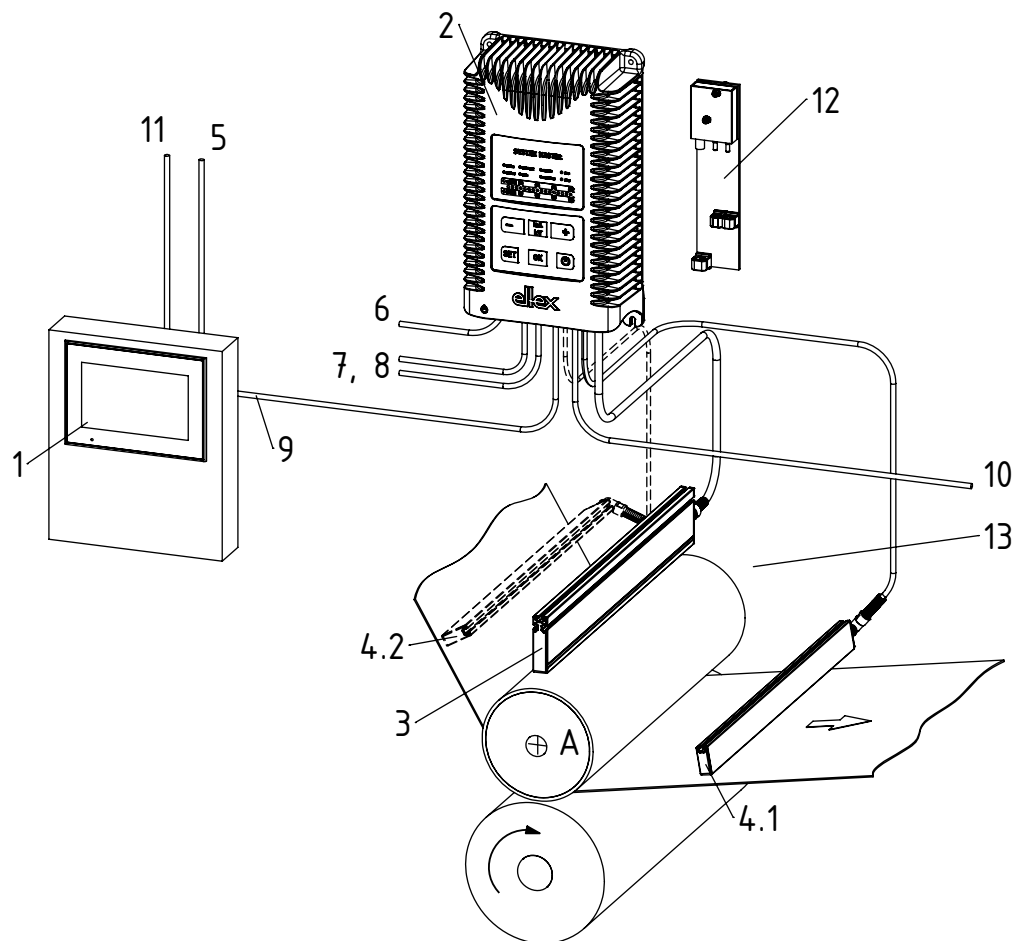

Fig 3:
Structure of the
ESA GNH63

Z-117540dy

1.4 System components

Item	Designation	Function	Type	Number
1 #	Visualization system Eltex Connected Control ECC or ECC software solution (supplied by Eltex)	The Eltex Connected Control ECC is a multifunctional control unit for the operation, visualization, parameterization and monitoring of supported end devices. It assumes the central role for controlling the entire fieldbus network and monitors the devices connected to it.	ECC_S/EG ECC_S/EH ECC_S/GG ECC_S/GH ECC_S/NG ECC_S/NH ECC_S/SU ECC_S/SE ECC_S/SP	1/system
2	High voltage generator (supplier Eltex)	Supplies impression roller electrodes and discharging electrodes with power and monitors the enable functions.	PCTL/_	1/PU*
3	Impression roller electrode (supplier Eltex)	Ensures the non-contacting charge transfer onto the impression roller. The high voltage cable ist part of the electrode.	R130A EXR130A3	1/PU*
4.1	Discharging electrode at the web outlet (supplier: Eltex)	Parasitic voltages after the printing nip are reduced by mounting a discharging electrode at the web outlet.	R50 EXR50	1/PU*
4.2 #	Discharging electrode at the web inlet (optional) (supplier Eltex)	To maintain controlled charge conditions in the printing nip, the paper resp. film web is neutralised with one more discharging electrode at the web inlet. The high voltage cable is part of the electrode.		1/PU*
A	2-layer impression roller or 3-layer impression roller (supplier customer)	The impression roller guarantees the even charge distribution in the printing nip.		1/PU*

Cable connections

Item	Designation	Connections on site (customer)	Type	Number
5 #	Mains lead visualization system ECC Power supply 24 V DC / 4.2 A DIN rail housing	Open cable end	KN/DD_ _ _ _ _ 115047	1/system
6	Mains lead generator	Open cable end	KN/GD_ _ _ _ _ (AC) KN/HD_ _ _ _ _ (DC)	1/PU
7	Release leads charging from the protective circuit to the generator	Open cable end	CS/AMO_ _ _ _ _	1/PU*
8	Release leads discharging from the protective circuit to the generator	Open cable end	CS/EMO_ _ _ _ _	1/PU*
9 #	CAN bus lead	Connection from the visualization system ECC to the next possible generator.	CS/CFMG_ _ _ _ _	1/system
10 #	CAN bus lead	Connection from one generator to next.	CS/CFMG_ _ _ _ _	∑ PU*-1
11 #	Control room integration visualization system ECC	T-distributor M12, 5-pin shielded customer connection as required (plug, socket, wire end ferrule)	114854 CS/C_ _ _ _ _	1/system
12 #	Electrode grounding (supplied by Eltex)	see details page 17	117174	1/PU*
13 #	Electrode bracket for Pos. 3, 4.1 and 4.2 #, not shown (supplied by Eltex or customer side)		machine specific	1/PU*
* PU = Printing unit				

2. Safety

The units have been designed, built and tested using state-of-the-art engineering, and have left the factory in a technically and operationally safe condition. If used improperly, the units may nevertheless be hazardous to personnel and may cause injury or damage. Read the operating instructions carefully and observe the safety instructions.

For warranty conditions, please refer to the General Terms and Conditions (GTC), see www.eltex.de.

2.1 Identification of risks and hazards

Possible risks and hazards resulting from the use of the units are referred to in these operating instructions by the following symbols:



Warning!

This symbol appearing in the operating instructions refers to operations which, if carried out improperly, may result in serious personal injuries.



Caution!

This symbol appearing in the operating instructions refers to operations which, if carried out improperly, may result in damage to property.



Ex Warning!

For units with EX approval only.

This symbol denotes the special conditions which must be observed when operating the system in explosion hazard areas as specified in the EX approvals.

2.2 Contact protection

The site of installation and/or use of the units is outside the control of Eltex, contact protection against inadvertent contact of the electrodes and of live components by personnel as specified by the employer's liability insurance association may have to be provided (e.g. DGUV V3 in Germany). Contact protection devices made of conductive material must be grounded.

Please note the information in the separate operating instructions for the appropriate electrodes R50 / EXR50 or R130A / EXR130A3.

2.3 Inspection of the protective resistors - contact protection

The function and the appearance of the protective resistors must be inspected at regular intervals. The inspection intervals are specified in the accident prevention regulations, as amended (e.g. in Germany DGUV V3).

Please observe the information in the separate operating instructions for the corresponding electrodes R50 / EXR50 or R130A / EXR130A3.

2.4 Technical advance

The manufacturer reserves the right to make changes to the technical specifications without prior notice in order to adapt the units to state-of-the-art engineering. Eltex will provide the latest information on any changes or modifications in the operating instructions on request.

2.5 Proper Use

The system ESA GNH63 must only be used for the non-contacting electrostatic printing assist on gravure printing machines. Impression roller electrodes and discharging electrodes are approved solely for use and operation with PCTL/ __ generator.

This ensures that:

- the maximum permissible charging voltage -30 kV / +20 kV is not exceeded,
- the maximum permissible discharging voltage of 5 kV AC is not exceeded,
- charging / discharging is not enabled until the release conditions are fulfilled (Chap. 3.1).

The manufacturer will not assume any liability and warranty if the system is used improperly or used outside the intended purpose.

Modifications or changes made to the system are not permitted.

Use only original Eltex spare parts and accessories.

2.6 Work and operational safety



Warning!

Please observe the following instructions and [chapter 2 "Safety", page 12](#) in their entirety and precisely!

Always observe the regulations for electrical equipment applicable in your country.

- Before installing, rectifying operating faults and performing cleaning and maintenance work on the units and the associated components, the power supply must be disconnected (see [chapter 5 "Maintenance", page 39](#), [chapter 6 "Trouble-shooting", page 42](#)).
- During any and all work, the machine on which the devices are installed must not be in operation (see [chapter 5 "Maintenance", page 39](#), [chapter 6 "Trouble-shooting", page 42](#)).
- All work on the devices may only be performed by qualified electricians (see [chapter 3 "Installation and assembly", page 19](#), [chapter 5 "Maintenance", page 39](#), [chapter 6 "Trouble-shooting", page 42](#)).

- If electrically conductive ink is used to print in a printing unit fitted with ESA, the ESA charging voltage must be disabled in this printing unit and in all following printing units. Discharging must also be switched off resp. moved to the "passive" operating mode (optional). If the passive operating mode is not available, the mains voltage of the generator must also be switched off.
- If electrically conductive substrates or substrates coated with conductive material (e.g. metal foil or metal composites) are used in the printing process, the ESA charging voltage must be disabled in these printing units, discharging must also be switched off resp. moved to the "passive" operating mode (optional). If the passive operating mode is not available, the mains voltage of the generator must also be switched off.
- If the conductive layers are enclosed in insulating layers in substrates coated with conductive material or in composites, make sure that the insulating layer is spared in the margin areas. The layer in this margin area must be grounded via an idler roller.
- The generator must be mounted in a safe zone and outside the explosion hazard area and must be operated only by trained and qualified electrical personnel.
- The electrodes passively absorb energy from the moving substrate web. The high voltage cable must be plugged in or grounded to the generator. If the high voltage cable is disconnected, the plug is live (high voltage) and applies with full power on the plug; this may cause a spark discharge and may lead to a risk of injury. Disconnected high voltage plugs are not permitted or have to be grounded (see [chapter 5 "Maintenance", page 39](#)).
- To guarantee the safe operation of the device, the described conditions (protective circuit, enabling, installation of the units, electrical connection etc.) must be observed. Refer to the notices in [chapter 3 "Installation and assembly", page 19](#).
- Before switching on the generator for the first time, make sure that the housing is permanently grounded via the ground clamp (7, Fig. 15). The ground cable should have a minimum cross section of 1.5 mm². Failure to observe this precaution can result in charges developing on the surface of the housing (see [chapter 3 "Installation and assembly", page 19](#)).
- If the web infeed is activated, the discharging function must be disabled (see [chapter 3.1 "Protective circuit, enable signals", page 19](#)).
- If the impression roller washing unit is activated, both the discharging and the charging function must be disabled (see [chapter 3.1 "Protective circuit, enable signals", page 19](#)).

- Do not enable the high voltage before a safe electrical contact is made between impression roller and impression cylinder (see [chapter 3.1 "Protective circuit, enable signals", page 19](#)).
- Do not use limit switches which only respond to the travel of the impression roller, because this configuration requires resetting each time the format is changed (see [chapter 3.1 "Protective circuit, enable signals", page 19](#)).
- The speed for enabling the discharging function must be > 0 (see [chapter 3.1 "Protective circuit, enable signals", page 19](#)).
- The plant operator is responsible for the proper function of the protective circuits. The protective circuit must be installed separately for each generator and each generator housing must be permanently grounded via the ground terminal (minimum cross-section 2.5 mm^2). Disconnect and/or connect the mains cable on the mains input socket of the generator only when the generator is switched off. The proper function of the protective circuit of each printing unit must be checked before putting the ESA into operation (see [chapter 3.1 "Protective circuit, enable signals", page 19](#)).
- A redundant release signal is required if the generator must comply with the safety requirements of DIN EN 13849. To this end, the two signals "Release +" and "Release -" must be transmitted via separate switching paths (see [chapter 3.1 "Protective circuit, enable signals", page 19](#)).
- The immediate surrounding of the impression roller and the impression roller electrode must be free of conductive materials in order to avoid sparking and damage to equipment. All conductive objects at a distance of up to 1 m from the impression roller electrode have to be grounded (see [chapter 3.2 "Impression roller environment", page 22](#)).
- To prevent leakage currents which might damage the electrode and the installation material, the following distances must be maintained during installation (see [chapter 3.3 "Assembling the impression roller electrode", page 24](#), [chapter 3.6 "Assembling the discharging electrode #", page 28](#)).
- The impression roller electrode has its place on the top half of the impression roller. The distance between electrode and impression roller should be between 5 and 8 mm. To avoid sparking between impression roller electrode and grounded machine parts, minimum distances must be maintained (see [chapter 3.2 "Impression roller environment", page 22](#), [chapter 3.3 "Assembling the impression roller electrode", page 24](#), [chapter 3.4 "Installation site and spacings for the impression roller electrode", page 25](#)).
- Recent findings have shown that due to a too small electrode spacing and high web speeds at the same time instead of the desired discharge

a polarity change takes place in the sense of charging. It is therefore strongly advised to adhere to the recommended installation distance (see [chapter 3.7 "Installation site and spacings for the discharging electrode #", page 30](#)).

- Disconnect and/or connect the mains cable on the mains output socket of the generator only when the generator is switched off (see [chapter 3.10 "Electrical connection", page 31](#)).
- When using external protection fusing for generators, the following circuit-breaker must be used: 6 A; tripping characteristic D (see [chapter 3.10 "Electrical connection", page 31](#)).
- Before activating the system the user must make sure that the installation and the connections are correct and functioning properly. The supply voltage can then be activated via the master switch of the printing machine.

The master switches of the generator and of the visualization system must be switched on at all times and are activated/deactivated via the master switch of the printing machine.

After activating the system, check the proper function of the protective circuit.

- **Note!**
If the visualization system is connected to the generators via the CAN bus, the unit can be operated only with the visualization system (as long as the parameter "keyboard lock" of the appropriate generator is set to active). In this case the generator will not respond to direct operation via the operating keys. Refer to the notices in [chapter 4 "Operation", page 32](#).
- Do not touch the screen of the visualization system with pointed or sharp objects! This may damage the touch sensitivity of the screen (see [chapter 4 "Operation", page 32](#), [chapter 5.4 "Visualization system Eltex Connected Control ECC #", page 41](#)).
- Check the components of the system at regular intervals for any damage to electric leads and high voltage cables. Any damaged components must be repaired or replaced before continuing to operate the units or the units must be disabled. Refer to the notices in [chapter 5 "Maintenance", page 39](#).
- **Warning!**
If the ESA system is switched off while the machine is running, any disconnected high voltage connectors must be grounded by qualified personnel! We recommend the use of our electrode grounding PC, see Fig. 3, Pos. 12. The electrodes passively absorb power from the running paper web. This can lead to spark discharges at the high voltage connector, endanger personnel and lead to fires in the explosion hazard area.

- The generator must be checked regularly to ensure its proper functioning. The cooling ribs must be kept clean and the connections of the high voltage cables must be free of dirt and other foreign matter (see [chapter 5.1 "High voltage generator", page 39](#)).
- If the housing cover is removed and the supply voltage is switched on at the same time, contact protection is no longer effective. Always disconnect the power before opening the devices.
- Make sure that the electrodes are clean at all times. Conductive pollution on the electrodes can cause fire. A large paper dust layer of more than 1 mm thickness is considered as a danger. Refer to the notices in [chapter 5.2 "Electrodes", page 39](#).
- To ensure the proper and trouble-free function of the electrodes, clean the electrodes regularly depending on pollution using compressed air free of oil and water (max. 6×10^5 Pa) and must be cleaned using a brush with soft plastic bristles. Do not damage the emission tips of the electrodes. Wait until the solvent has evaporated before putting the generator back into operation to avoid a risk of deflagration (see [chapter 5.2 "Electrodes", page 39](#)).
- In explosion hazard areas Group II Gas it must be ensured that the possibility of the discharge pins being effectively connected together, e.g. by dirt or contamination, is avoided (see [chapter 5.2 "Electrodes", page 39](#)).
- Depending on operating conditions, the emission tips are subject to more or less wear and tear. If the tips have burned off to a distance of 1 mm from the casting compound, a new electrode is to be fitted (see [chapter 5.2 "Electrodes", page 39](#)).
- Immediately replace an electrode as soon as it shows burning traces, e.g. caused by fire in the printing unit or by leakage currents. Do not continue operating the electrode. Cleaning a damaged electrode will not eliminate the risk of fire (see [chapter 5.2 "Electrodes", page 39](#)).
- When cleaning the impression roller or the electrode with a cloth soaked in solvent, or during automatic washing with solvent and spray bar, the electrode bodies and emission tips are necessarily wetted with liquid solvent. This will impair the regular function of the impression roller electrode / discharging electrode. Do not restart the generator before the solvent has evaporated (see [chapter 5.2 "Electrodes", page 39](#)).
- Operation of impression roller washing units while the machine is running!
For safety reasons, the discharge electrodes of all Eltex ESA systems are activated with the signal "machine speed >0". If impression roller washing units have been installed which operate at >0 machine speed, the discharge electrodes must also be deactivated; wetting of the elec-

trode surfaces with solvent cannot be ruled out (see [chapter 5.2 "Electrodes", page 39](#)).

- Do not touch the emission tips of the electrode if the high voltage supply is connected!
If the high voltage supply is connected, reflex responses to electrical irritation can lead to secondary accidents; the charging electrode as such is safe to touch. If contact is made (≤ 10 tips), the energy transferred is so low that there is no risk of injury.
- Potential risk for wearers of cardiac pacemakers:
Moving the chest closer than 3.5 cm to the emission tips of the discharge electrode or making surface contact with several emission tips (touching a single tip is not critical) can result in a temporary switchover of the cardiac pacemaker into the fault mode. Permanent proximity or contact can therefore cause severe problems. If it is likely that the chest of such a person comes closer than 3.5 cm to the emission tips of the discharge electrode, or if several emission tips are touched at the same time, the appropriate warning notices must be displayed.
- The operation of the electrodes can generate ozone. The ozone concentration levels developing near the electrodes depend on many different factors such as site of installation, electrode current and voltage, air circulation, etc., and can therefore not be specified in general terms. If the maximum allowable concentration of ozone must be observed at the site of installation of the electrode, the concentration must be measured on site.
The AGW value (maximum admissible concentration) serves to assess the ozone concentration at the workplace. The user must make sure that the appropriate national AGW value is at no times exceeded, e.g. in Germany the ozone concentration occurring during the operation of the system must not exceed the recommended value based on international limits of 0.06 ml/m^3 (0.12 mg/m^3).
- **Charges developing on personnel**
When working near the electrodes ($<1 \text{ m}$), always wear conductive footwear. Please note all national regulations regarding electrostatic charge. (e.g. TRGS 727 in Germany, "Vermeidung von Zündgefahren infolge elektrostatischer Aufladung").

3. Installation and assembly

3.1 Protective circuit, enable signals

The protective circuit has the following functions:

Protective circuit installed by customer	Generator
Master switch of machine ON	Supply voltage ON
Machine speed >0 m/s and printing unit engaged and impression roller washing unit not active and web infeed not active	Enable discharging #
Machine speed >0.4 m/s and no web break and no emergency stop and impression roller in working position	Enable charging

To guarantee the safe operation of the system in the printing unit even under explosion-hazard conditions, the following enabling conditions must be observed.

Web infeed active



Warning!

If the web infeed is activated, the discharging function must be disabled.

Impression roller washing unit active



Warning!

If the impression roller washing unit is activated, both the discharging and the charging function must be disabled. If the discharging electrodes are covered in solvent during the impression roller washing process, the charging and discharging function must not be enabled before the electrodes and the impression roller are completely dry.

Impression roller contact



Warning!

Do not enable the high voltage before a safe electrical contact is made between impression roller and impression cylinder!

For the lift-off of the impression roller the protective circuit must be designed such that the enabling mechanism of the high voltage is switched off before the impression roller lifts off, i.e. before there is no longer any contact with the paper and the impression cylinder.

This can be implemented by one of the following methods:

- use of hydraulic or pneumatic pressure switches which respond to the increase in pressure (back pressure) after setting down the impression roller, provided that this pressure is high enough (PRESSOSTAT).
- limit switches or initiators may be used if the impression roller is lowered mechanically, provided that an appropriate overtravel corresponding to the line pressure is available after setting down, e.g. via an eccentric shaft.



Caution!

Do not use limit switches which only respond to the travel of the impression roller, because this configuration requires resetting each time the format is changed.

The best possible option with respect to safety is a switch signal supplied by the machine manufacturer which indicates that the impression roller makes contact with an adequate line pressure, e.g. 15 N/mm (PRESSOSTAT).

If the impression roller is allowed to lift off before the applied voltage is switched off, sparking may occur. This must be avoided at all cost. There is an operating condition in proofing presses where the impression roller can be lifted off during printing, which is known as progs. In this case, the charge enable function must be switched off immediately after this command is detected. In any case, every precaution must be taken to ensure that a stop during the lowering process immediately results in the enable function to be switched off.

Web break

The charge enable function must be switched off by the protective circuit of all connected generators immediately after a web break occurs. Some machines allow the operator to continue in spite of the web break sensor responding (web break override). Blocking the enable function must be safeguarded in this case.

Minimum speed

Since the speed in a press with several printing units is the same in all printing units, it is sufficient to fit a speed-dependent switch (ramp function generator) which acts on the protective circuits of the individual generators. The minimum printing speed for enabling the charging function is >0.4 m/s. Basically, the enabling function should set in just below the minimum production speed. After charging has been enabled, maintenance and cleaning work is no longer permitted! If necessary, charging should be enabled at higher speeds.

The speed for enabling the discharging function must be > 0.





Protective circuit

Caution!

The plant operator is responsible for the proper function of the protective circuits.

The protective circuit must be installed separately for each generator. Disconnect and/or connect the mains cable on the mains input socket of the generator only when the generator is switched off.

The proper function of the protective circuit of each printing unit must be checked before putting the ESA into operation.

Each generator housing must be permanently grounded via the ground terminal (minimum cross-section 2.5 mm²).

Note!

When using external protection fusing for generators, the following power protection must be used: 6A; tripping characteristic D complying with DIN EN 60898-1 (VDE 0641-11).

A protective circuit of the following type must be implemented for each printing unit:

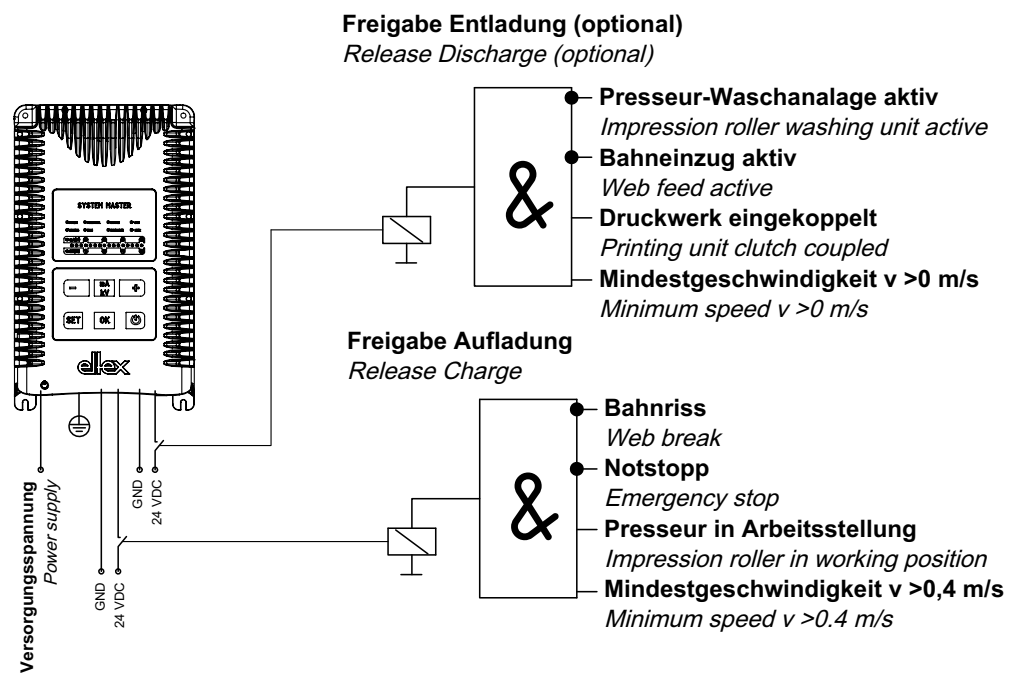

Fig 4:
Protective circuit
for each printing
unit of the ESA



A redundant release signal is required if the generator must comply with the safety requirements of DIN EN 13849. To this end, the two signals “Release +” and “Release -” must be transmitted via separate switching paths.

3.2 Impression roller environment

The impression roller is to be assembled by the plant operator (design and measurement regulations for the impression roller, see Annex).

The minimum distances are specified in the following table:

Element	Measure
Limit switch	Minimum distance from impression roller: min. 10 mm
Splash proofing	Minimum distance from impression roller: min. 10 mm Use plastic material if the distance is smaller. When operating the unit in explosive atmospheres, note the regulations concerning plastics (e.g. TRGS 727 in Germany).
Automatic cleaning device for impression roller and impression cylinder	Guide shield and screws with a distance to the impression roller ≤ 5 mm have to be replaced with plastic elements. Caution! Do not switch on the cleaning device as long as the ESA system is in operation.
Backing roller	Must be coated with insulating layer or film, insulating film ELM00606 made of PTFE self-adhesive, width: 1.000 mm, breakdown strength of the insulation: >30 kV
Impression roller removal pivot	Minimum distance from impression roller 10 mm, sharp edges to be rounded.
Cowling over impression roller	The space required for the impression roller must be maintained to ensure proper cleaning.



The immediate surrounding of the impression roller and the impression roller electrode must be free of conductive materials in order to avoid sparking and damage to equipment.

All conductive objects at a distance of up to 1 m from the impression roller electrode have to be grounded (observe maintenance instructions).

The following figure shows the areas around the impression roller in which conductive materials can lead to malfunctions.

Fig. 5:
 Keep the operating area of the impression roller electrode and of the impression roller free of conductive material, shaded area = zone free of conductive material

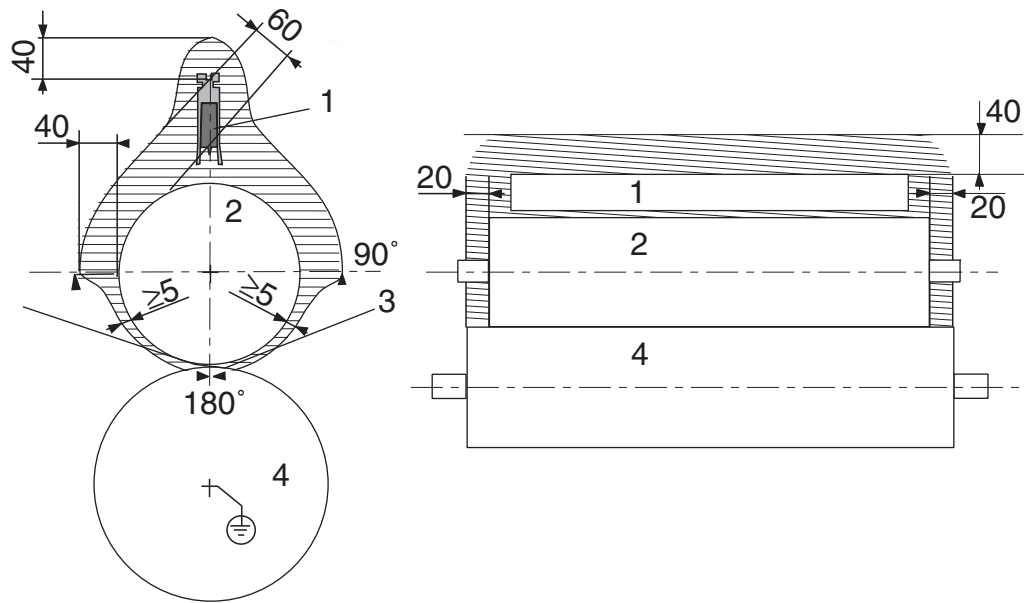

- 1 Impression roller electrode
- 2 Impression roller
- 3 Paper
- 4 Impression cylinder

If isolated metal with a breakdown strength of the insulation of >30 kV is used, these objects can be mounted 10 mm closer to the impression roller and/or the impression roller electrode than shown in the figure.

Z00306Y

3.3 Assembling the impression roller electrode

Attach the electrodes to the machine using flame-retarding GRP installation material (rod). An example of the installation mode is given in the figure. The electrode is attached to the GRP rod via plastic holders which are plugged into one of three assembly grooves. The GRP rod is attached to the machine via a light-metal socket and a perforated piece of sheet metal. To prevent the electrode from sagging, an angle bracket is bolted to the GRP rod if long electrodes are used.

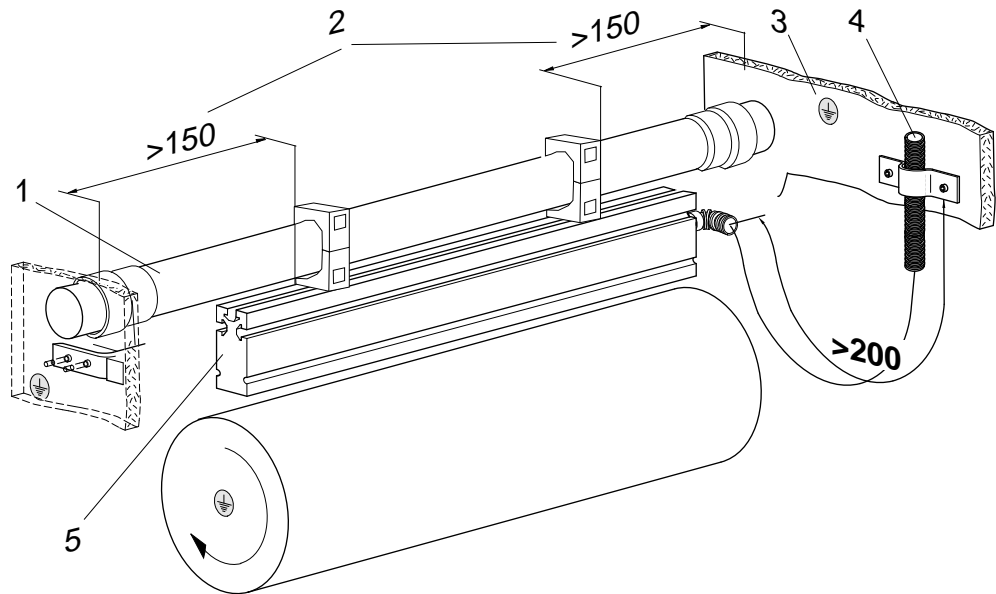

Fig 6:
Assembly example
of the impression
roller electrode

- | | |
|----------------------|---|
| 1 GRP rod | 4 high voltage cable with protection tube |
| 2 creepage distances | 5 electrode |
| 3 machine wall | |



To prevent leakage currents which might damage the electrode and the installation material, the following distances must be maintained during installation:

- No conductive material to be present at a distance of 40 mm from the impression roller electrode.
Exception: clearances of >5 mm are allowed in the area of the assembly grooves. These points must be monitored for any fouling.
- A creepage distance of >150 mm between impression roller electrode and ground potential must be maintained.
- The h.v. cable must be routed in free air for a minimum of 200 mm before attaching it to the machine wall.
- The distance between impression roller electrode and the impression roller surface must be between 5 and 8 mm.



3.4 Installation site and spacings for the impression roller electrode

The impression roller electrode has its place on the top half of the impression roller. The distance between electrode and impression roller should be between 5 and 8 mm.

To avoid sparking between impression roller electrode and grounded machine parts, minimum distances must be maintained (see Chap. 3.2 and Chap. 3.3).

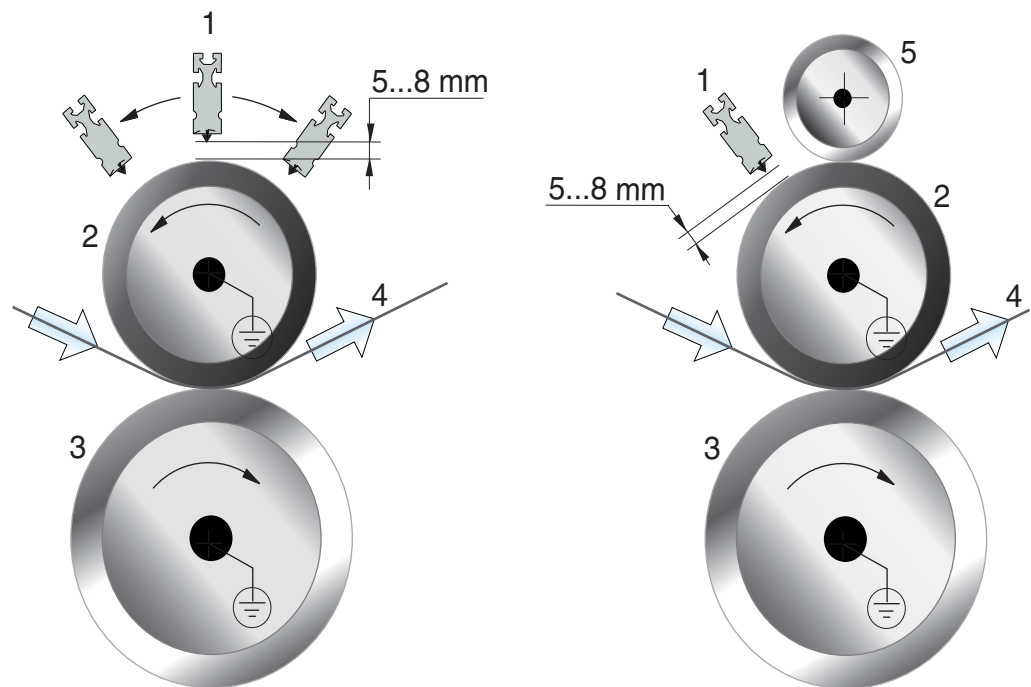

Fig. 7:
Positioning the
impression roller
electrode,
right side in a
system with
support
impression roller

- 1 *impression roller electrode*
- 2 *impression roller*
- 3 *printing cylinder*
- 4 *substrate web*
- 5 *support impression roller*

For optimum function, line the support impression roller (if fitted) with an insulating coating or film.

Z00464y + Z00465y

3.5 Design of the impression roller electrode

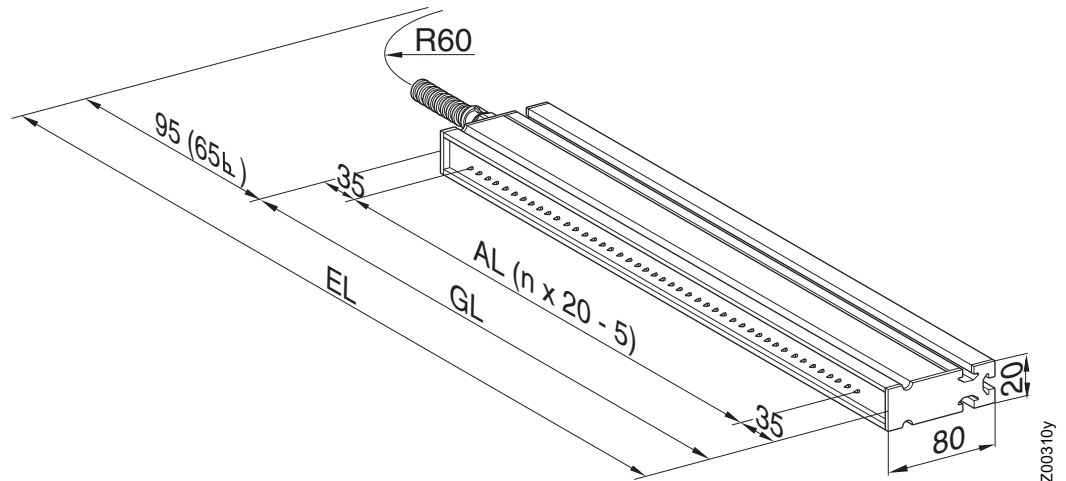

Fig 8:
Impression roller
electrode

AL active length
GL total length
EL installation
length

Calculating the active length

The even and regular effect of the ESA over the entire paper width is determined by the impression roller electrode. Make sure that the active length of the impression roller electrode is in relation to the length of the impression roller.

Using the equation $I_{K \min} = I_B / 2.5$ checking the configuration is relatively easy.

Operating current segment $I_B = A + (\pi B / 2)$

Fig 9:
Determining the
active electrode
length

A spacing of the
impression
roller electrode
B \varnothing of semi
conductor
C \varnothing of steel core

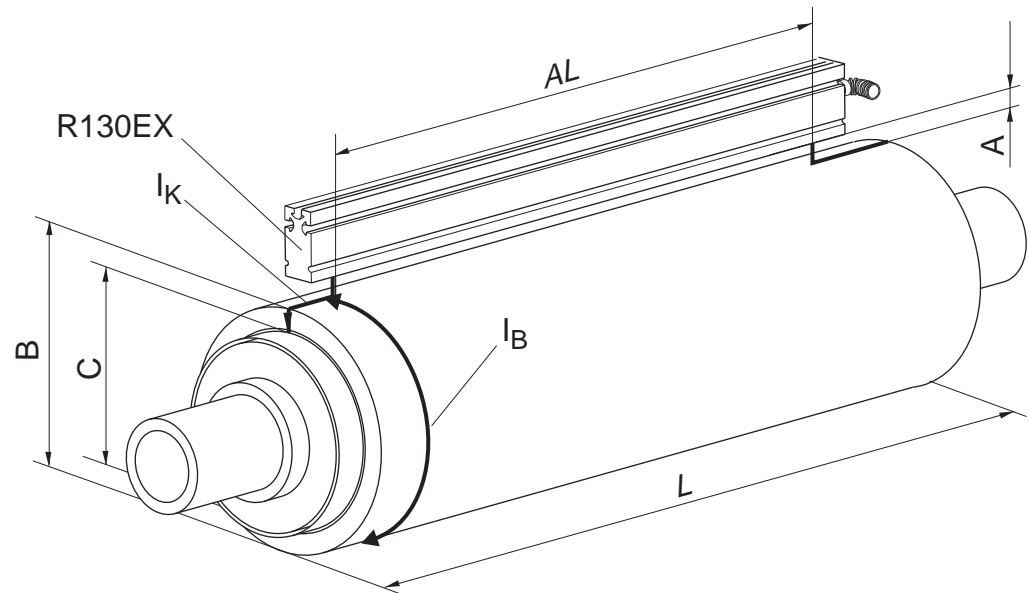

L layer distance of impression roller I_B operating voltage distance
AL active length of the electrode I_K creepage distance

Calculation example:

Impression roller specification: L = 1000 mm; B = 150 mm; C = 130 mm

Electrode spacing: A = 8 mm

The active length (AL) of the impression roller electrode is to be determined:

$$l_B = 8 + (\pi 150/2) \Rightarrow l_B = 244 \text{ mm}$$

$$l_{K \text{ min}} = l_B/2.5 \Rightarrow l_K = 244/2.5 \Rightarrow l_K = 98 \text{ mm}$$

Ergo: AL calculated as follows:

$$\mathbf{AL = 2A + L + B - C - 2l_K = 835 \text{ mm}}$$

The electrode is available only in the grid matrix 20 mm, the selected active length (AL) is therefore determined with 840 mm.

On principle, the total length of the electrode must not be greater than the maximum paper web width and should not be shorter than the coating length of the impression roller minus 200 mm. If necessary, the calculation results must be adjusted accordingly.

3.6 Assembling the discharging electrode

Install the R50 / EXR50 / RG52C discharging electrode with GRP round bars which can be attached to the side of the machine wall with various bracket mountings (e.g. perforated sheet metal plates). The electrode itself is attached to the GRP rod with plastic holders engaging in the assembly groove.

Plastic holders:

- below 1 m total length 3 per electrode
- below 2 m total length 5 per electrode
- below 3 m total length 7 per electrode
- below 4 m total length 9 per electrode

For long electrodes use an additional angle bracket attached to the GRP rod to prevent the electrode from sagging.

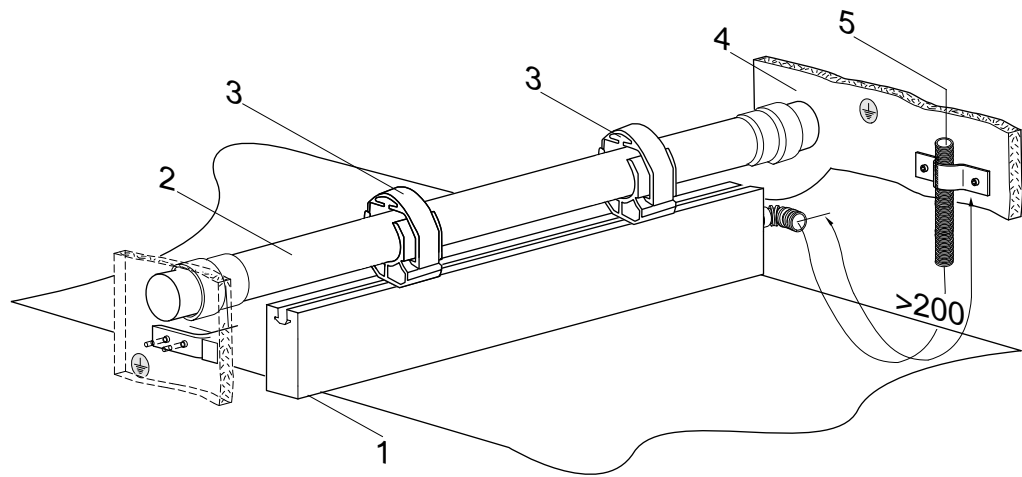

Fig 10:
Assembling the
discharging
electrode

- 1 Electrode
- 2 GRP rod
- 3 Fastening clip
- 4 Machine wall
- 5 High voltage cable with protection tube

Alternatively, attach the discharging electrodes to the machine wall using flame-retarding GRP material. For easy installation it is advisable to use the assembly material offered by Eltex.

The assembly rail of the electrode is grooved. Sliding nuts pushed into these grooves hold the GRP material and so allow the installation of the electrode.

Sliding nuts and bolts made of plastic:
 below 1 m total length 2 sliding nuts per electrode
 below 2 m total length 3 sliding nuts per electrode
 below 3 m total length 4 sliding nuts per electrode
 below 4 m total length 5 sliding nuts per electrode

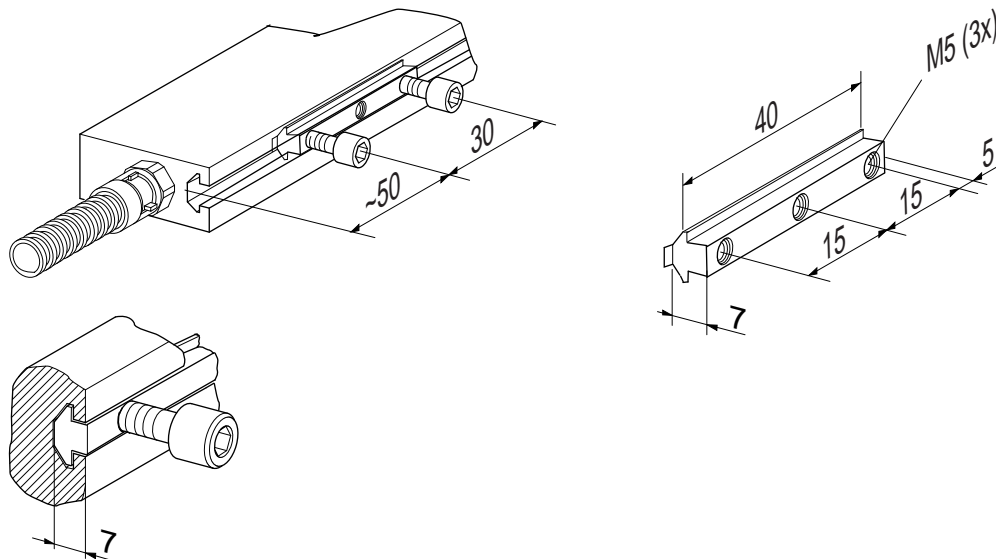

Fig 11:
 Assembling with
 sliding nuts

Z00335y

- Maximum bolt depth 6.5 mm
- Torque 0.4 Nm
- Secure bolts in place (e.g. Loctite 243)



Caution!

To prevent leakage currents which might damage the electrode and the installation material, the following distances must be maintained during installation:

- the high voltage cable must be routed in free air for a minimum of 200 mm before attaching it to the machine.
- the distance between the discharging electrode and the paper must be between 30...100 mm.

3.7 Installation site and spacings for the discharging electrode

The discharging electrode must be installed as shown in the figure.

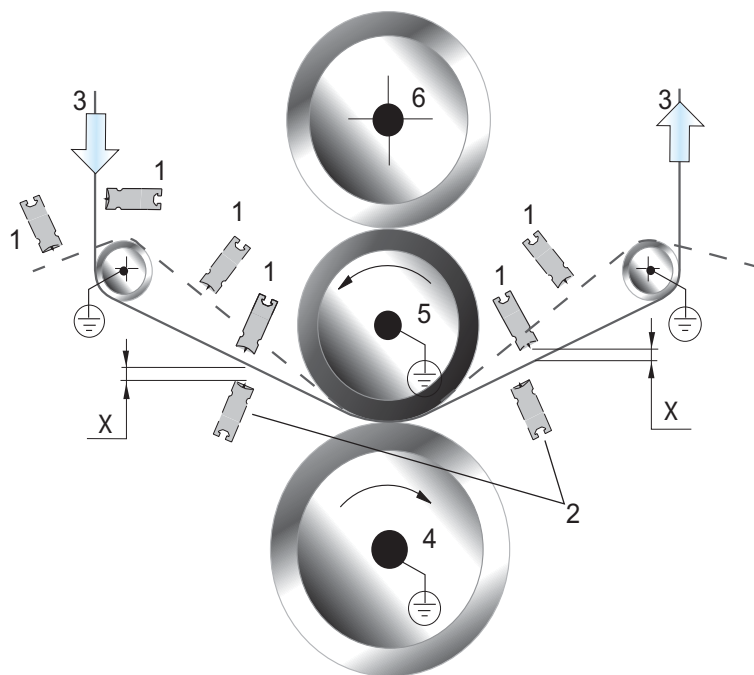

Fig 12:
Positioning the
discharging
electrode

- 1 Discharging electrode (depending on different web guide)
 - 2 Alternative installation of discharging electrode for paper printing
 - 3 Material web
 - 4 Printing cylinder
 - 5 Impression roller
 - 6 Support impression roller
- X The distance to the material web surface should be in the range between 30... 100 mm. The ideal range is 40... 70 mm.*



Recent findings have shown that due to a too small electrode spacing and high web speeds at the same time instead of the desired discharge a polarity change takes place in the sense of charging. It is therefore strongly advised to adhere to the recommended installation distance. If this is not possible due to the space available, the system can be operated by passive switching of the active discharge electrodes, then the system can be operated without or only with less negative polarity charging even at a smaller distance of the discharge electrodes to the material surface.

In particular, when printing on film or composite materials, we recommend to observe the facts described above.

Ideally, for paper / carton applications the discharging electrode is mounted directly after the press line. This configuration is recommended particularly for distances between the impression roller and the idler roller >600 mm. When printing on film discharging electrode must be mounted

directly after the press line.

The installation of one discharging electrode in the inlet/outlet is sufficient.

Rule of thumb: mount the electrodes as far removed from the impression roller and the rollers as possible.

3.8 High voltage generator

Please observe further device-specific information in the separate operating instructions of the high voltage generator POWER CHARGER PC.

3.9 Visualization system Eltex Connected Control ECC

Please observe further device-specific information in the separate operating instructions of the visualisazion system Eltex Connected control ECC.

3.10 Electrical connection

The following electrical connections must be made:

- Protective circuits to be provided by the customer with enable leads to the generators, connection to the analog interface
- Supply voltage to generators and visualization system
- Connecting the CAN bus between the generators and the visualization system
- High voltage cable of the impression roller electrode to the generator
- High voltage cable of the discharging electrodes (feed and delivery side) to the generator #
- Ground connection of all generators with a minimum cross section of $2,5 \text{ mm}^2$



Warning!

Disconnect and/or connect the mains cable on the mains output socket of the generator only when the generator is switched off.

When using external protection fusing for generators, the following circuit-breaker must be used: 6 A; tripping characteristic D in compliance with DIN EN 60898-1 (VDE 0641-11).

4. Operation

4.1 Startup

Before activating the system the user must make sure that the installation and the connections are correct and functioning properly. The supply voltage can then be activated via the master switch of the printing machine.

The operation of the generators and/or of the visualization system is shown on each unit via the display message.

The master switches of the generator and of the visualization system must be switched on at all times and are activated/deactivated via the master switch of the printing machine.

After activating the system, check the proper function of the protective circuit.

Note!

If the visualization system is connected to the generators via the CAN bus, the unit can be operated only with the visualization system.

In this case the generator will not respond to direct operation via the operating keys.



Caution!

Do not touch the screen of the visualization system with pointed or sharp objects! This may damage the touch sensitivity of the screen!

4.2 ESA operating mode

Note!

If the unit is operated via the ECC visualization system, the operating mode will be set automatically by the film-paper selection.

When operating the unit via the generator, the operating mode must be selected explicitly. (see Chap. 4.4).

When printing on paper, select the operating mode Current Constant, when printing film, select the operating mode Voltage Constant.

Unlike the Voltage Constant operation, the Current Constant mode of operation has the advantage that (within certain limits), changes the electrode spacing and pollution can be compensated and remains without effect on the printing result.

Current Constant operation requires a current flow between the impression roller and the impression cylinder. This condition is met in illustration gravure printing.

Depending on the printing substrate, the following must be noted in packaging and decorative printing:



- If the impression roller is isolated from the impression cylinder by high resistance film or thick carton safety reasons dictate that the Voltage Constant operation is always selected in the hazardous zone.
- This means **when printing on paper, select the operating mode Current Constant (paper printing), when printing film or thick carton, select the operating mode Voltage Constant (film printing).**

4.3 Setpoint setting

The correctly selected setpoint guarantees missing-dot-free printing results. The general recommendation is: select only as much electrical output power which is necessary for eliminating missing dots. An excessively high electrical output power causes more severe pollution.

Guide values for setpoint setting when printing paper:
50% (1.3 mA per meter of printing unit width)

Guide values for setpoint setting when printing film:
30% (4 kV)

The values shown in brackets apply to operation without visualization system, settings selected directly at the generator.

These values only serve as setting aid. The setpoint is optimized at the first point at which no missing dots occur.

Important! Excessive ESA output power results in increased impression roller pollution! Polluted impression rollers need higher ESA power to penetrate the layer of dirt. This leads to even more impression roller pollution - a vicious circle, especially when LWC productions are started with too much power.

4.4 Operating the system directly via the generator POWER CHARGER PCTL

Please see all further device-specific information in the separate operating instructions of the high voltage generator POWER CHARGER PC.

Setting the setpoint of the generator power,
details see Chap. 4.3 Setpoint setting

4.5 Operating the system via the visualization system Eltex Connected Control ECC

Please observe all further device-specific information in the separate operating instructions of the Eltex Connected Control ECC, if you are using the visualization system ECC.



Fig. 13:
Startup

All relevant settings can be made via the ECC visualization system. All current process data, states and corresponding error or warning messages are displayed and the enabling or disabling of the high voltage and the acknowledgment of the corresponding messages are possible. An individual view and optimal display are freely configurable and allow high operating comfort for every application.

4.5.1 Rapid start-up

Printing units, generators and visualization system are switched on, the machine is enabled:

Variant 1

- select preset parameters via "Preset"
- mark the parameter set
- load the parameter set

Variant 2

- Set the desired setpoint for each generator, if desired, then save it in the visualization system as a parameter set.

4.5.2 Emergency operation without visualization system ECC

Should the visualization system fail, the direct operation of the generators is enabled after 5 seconds. All settings can then be made directly at the generators; see operating instructions of the high voltage generator POWER CHARGER, Chap. 4 "Operation".

4.6 Operating the system via the control room integration

With the support of standardized fieldbus protocols, the system can directly be integrated into a machine network. Details for the integration into the control room or the machine control can be found in the separate device and protocol descriptions. Please also note the chapter "Installation" in the operating instructions of the POWER CHARGER generator.

4.6.1 Functions and default settings, Charging parameters

Function	Description	Setting options	Default setting
Setpoint Charging	Setting the setpoint of the charging in percent for conversion to the absolute value	0 - 100 %	5 %
Operation mode Charging	Selection of the operating status of the charging	ESA paper ESA film ESA metallised materials	ESA film
Setpoint Voltage Charging	Optional setting of the high voltage setpoint	1,500 V - 30,000 V PCTL/ _N_ _ _ _ E: 1,500 V - 27,000 V PCTL/ _P_ _ _ _ E: 1,500 V - 18,000 V	1,500 V
Setpoint Current Charging	Optional setting of the current setpoint	PCTL/ _ _ _ L, PCTL/ _ _ _ S: 50 µA - 3,750 µA PCTL/ _ _ _ H: 50 µA - 7,500 µA	PCTL/ _ _ _ L, PCTL/ _ _ _ S: 3,750 µA PCTL/ _ _ _ H 7,500 µA
Ramp time Charging	Ramp-up time of the high voltage	100 mx - 10,000 ms	500 ms
Hard flashes Factor	Setting of the sensitivity for the detection of hard flashes	25 % - 40 %	25 %
Soft flashes Factor	Setting of the sensitivity for the detection of soft flashes	10 % - 25 %	10 %
Limit Flash counter	Limit for the detection of errors or warnings of the respective flash counter	0 - 1,000 (0: setting deactivated)	10
Nominal resistance Charging	Determined standardized resistance of the charge for the detection of pollution	0 kΩ - 1,000,000 kΩ	0 kΩ

4.6.2 Function and factory settings, Discharging parameters #)

Function	Description	Setting options	Factory setting
Setpoint Discharge	Setting of the setpoint of the discharging in percent	0 % - 100 %	100 %
Operating mode Discharge	Setting of the mode discharge	<ul style="list-style-type: none"> • Passive discharge • Active discharge 	Passive discharge
Parameter adjustment Discharge	Setting of the parameter adjustment to optimize the discharge	0 % - 100 %	0 %

Only for device variants with active discharge (PCTL/A and PCTL/C)

Setpoint Discharge	Adjustment of the voltage Discharge	3,500 V - 5,000 V	5.000 V
--------------------	-------------------------------------	-------------------	---------

Only for device variants with monitored discharge (PCTL/C and PCTL/P)

Active length discharging electrode 1	Adjustment of the active length of the discharging electrode 1	0 mm - 5,000 mm	0 mm
Active length discharging electrode 2	Adjustment of the active length of the discharging electrode 2	0 mm - 5,000 mm	0 mm

4.6.3 Functions and default settings, General parameters

Function	Description	Setting options	Default setting
High voltage Release Mode	Release mode of the high voltage	<ul style="list-style-type: none"> Autostart Analog setpoint HMI Fieldbus 	Fieldbus
Pollution monitoring	Pollution detection of the charging or discharging electrode	<ul style="list-style-type: none"> OFF Charging ON Charging calibration 	OFF
LED Balken Modus	Switching the view of the LED bar of the generator	<ul style="list-style-type: none"> Voltage Current 	Voltage
Keyboard lock	Deactivation or activation of the keyboard lock for setting directly at the generator	<ul style="list-style-type: none"> Inactive Active 	Inactive (Stand-alone-mode) Active (operation with ECC)

4.6.4 Functions and default settings, Interface parameters

Function	Description	Setting options	Default setting
Analog Setpoint	Selection of the setpoint setting with analog interface	<ul style="list-style-type: none"> OFF Current 0 - 20 mA Voltage 0 - 10 V OFF + limiter signal Current 0 - 20 mA and limiter signal Voltage 0 - 10 V and limiter signal 	OFF
Only for device versions with CANopen® interface			
CANopen® node address	Node address setting of the CANopen® network	1 - 127	99
CANopen® Baud rate	Baud rate setting of the CANopen® network	10 kBit/s, 25 kBit/s, 50 kBit/s, 125 kBit/s, 250 kBit/s, 500 kBit/s, 800 kBit/s, 1000 kBit/s	125 kBit/s

5. Maintenance



Warning!

Electric shock hazard!

- Do not carry out any maintenance or repair work without first switching off the high voltage generator and disconnecting the supply voltage.
- The electrodes passively absorb energy from the moving substrate web. The high voltage cable must be plugged in or grounded to the generator. If the high voltage cable is disconnected, the plug is live (high voltage) and applies with full power on the plug; this may cause a spark discharge and may lead to a risk of injury. Disconnected high voltage plugs are not permitted or have to be grounded.
- The machine on which the devices are installed must not be in operation.
- Repairs and maintenance work may only be performed by qualified electricians.

5.1 High voltage generator

The generator must be checked regularly to ensure its proper functioning. The cooling ribs must be kept clean and the connections of the high voltage cables must be free of dirt and other foreign matter. The intervals for the check depend on the application and must hence be defined by the user according to the operating conditions. The generator itself does not require any maintenance.

Please observe further device-specific information in the separate operating instructions of the high voltage generator POWER CHARGER PC.

5.2 Electrodes



Warning!

Risk of injury!

Do not touch the emission tips of the electrodes.

To ensure the proper and trouble-free function of the electrodes, clean the electrodes regularly depending on pollution using compressed air free of oil and water (max. 6×10^5 Pa) and a brush with soft plastic bristles (see [chapter 7 "Spare parts and accessories", page 44](#)).

Deposits of grease, glue, ink etc. on the electrodes must be cleaned off with the solvent normally used in the respective printing process. Do not immerse electrodes and high voltage cables in solvent!

If polluted heavily, clean the electrodes at shorter intervals. Remove any dust deposits and fluff from the electrodes or close to the electrodes. A large paper dust layer of more than 1 mm thickness is considered as a danger.



In explosion hazard areas Group II Gas it must be ensured that the possibility of the discharge pins being effectively connected together, e.g. by dirt or contamination, is avoided.

Brush off the electrodes every time the press is at standstill, even if the pollution monitoring function shows no error.

Clean electrodes will discharge much better, if electrodes are cleaned regularly, dirt can be removed much easier.



Warning!

Depending on operating conditions, the emission tips are subject to more or less wear and tear. If the tips have burned off to a distance of 1 mm from the casting compound, a new electrode is to be fitted.



Warning!

Risk of fire!

Immediately replace an electrode as soon as it shows burning traces, e.g. caused by fire in the printing unit or by leakage currents. Do not continue operating the electrode. Cleaning a damaged electrode will not eliminate the risk of fire!



Warning!

Risk of deflagration!

When cleaning the impression roller or the electrode with a cloth soaked in solvent, or during automatic washing with solvent and spray bar, the electrode bodies and emission tips are necessarily wetted with liquid solvent. This will impair the regular function of the impression roller electrode / discharging electrode. Do not restart the generator before the solvent has evaporated.



Warning!!

Operation of impression roller washing units while the machine is running! For safety reasons, the discharge electrodes of all Eltex ESA systems are activated with the signal "machine speed >0". If impression roller washing units have been installed which operate at >0 machine speed, the discharge electrodes must also be deactivated; wetting of the electrode surfaces with solvent cannot be ruled out.

5.3 Inspection of the protective resistors - contact protection

The function and the appearance of the protective resistors must be inspected at regular intervals. The inspection intervals are specified in the accident prevention regulations, as amended (e.g. in Germany DGUV V3).

Please observe the information in the separate operating instructions for the corresponding electrodes R50 / EXR50 or R130A / EXR130A3.

5.4 Visualization system Eltex Connected Control ECC

The visualization system don't require any maintenance.

The Touch Screen can be cleaned with a standard cleaning agent for LCD monitors (IT devices).



Caution!

Do not touch the screen of the visualization system with pointed or sharp objects! This may damage the touch sensitivity of the screen!

6. Trouble-shooting

6.1 Error messages Visualization system Eltex Connected Control ECC

Error messages and measures appear in plain text on the display of the visualization system. Besides messages on soiled electrodes, all generator error messages may appear.

6.2 Error messages Generator



Warning!

Electric shock hazard!

- Do not carry out any maintenance or repair work without first deactivating the generator and disconnecting the supply voltage.
- The machine which has the units fitted must not be in operation.
- Repairs and maintenance work may only be performed by qualified electricians.

Defect/error	Defect/cause	Remedy
Numbers of Missing dots	<ul style="list-style-type: none"> • Dirty electrodes. • Electrodes soiled by water-silicon-emulsion • Unsuitable conditions (paper too moist, mineral content of the paper too high, unprinted surfaces). 	<ul style="list-style-type: none"> • Clean electrodes. • Install trap / guard for water-silicon-emulsion, clean electrodes, if necessary, install hot-air dryer after water-silicon application station. • Adapt operating conditions to the requirements of ribbon tacking as far as possible (see Chap. 1.2).
Generator cannot be switched on	<ul style="list-style-type: none"> • Defective fuse. • Supply voltage not connected. 	<ul style="list-style-type: none"> • Replace fuse (see name plate). • Activate or connect supply voltage.
Decrease in efficiency	Polluted charging electrode / mounting	<p>Clean the electrodes / mountings using compressed air free of oil and water and a brush with soft plastic bristles. Use a suitable solvent to remove dirt or grease (see Chap. 5 "Maintenance"). (No continuous sparking (electric arc) must be visible on the electrode tips).</p> <p>Caution! Do not immerse the charging electrode in solvent.</p>

Decrease in efficiency	Defective charging electrode	<p>Check the charging element for any defects which may be caused by creepage currents.</p> <p>Replace the charging electrode and install it to make sure that creepage currents can not develop. See chap. 3 "Installation and assembly".</p>
Decrease in efficiency	Worn charging electrode	<p>Depending on application, the emission tips are subject to more or less wear and tear. If the tips have burnt down to a distance of 3 mm from the encapsulating compound, replace the charging electrode.</p>

7. Spare parts and accessories

Article	Reference code
High voltage generator (Execution of cable connection and connector type after consultation with ELTEX)	PCTL/_ _
Impression roller electrode (specify active length of electrode and cable)	R130A
Impression roller electrode for installation in EX zone (specify active length of electrode and cable)	EXR130A3/_ _ _
Discharging electrode (specify active length of electrode and cable)	R50/_ _ _
Discharging electrode for installation in EX zone (specify active length of electrode and cable)	EXR50/_ _ _
Mounting material for electrodes: slide nut with screws and washers	105826
Electrode grounding PC	117174
Interface cable, analog interface generator Charging open cable end on customer side (specify length)	CS/AMO_ _ _ _ _
Interface cable, analog interface generator Discharging open cable end on customer side (specify length)	CS/EMO_ _ _ _ _
Mains cable generator, AC open cable end on customer side (specify length)	KN/GD_ _ _ _ _
Mains cable generator, DC open cable end on customer side (specify length)	KN/HD_ _ _ _ _
CAN bus cable, CAN bus plug both ends 1x male, 1x female (specify cable length)	CS/FMG_ _ _ _ _
T-distributor M12, 5-pin shielded	114854
Mains cable visualization system open cable end on customer side (specify length)	KN/DD_ _ _ _
Power supply DIN Rail 24 V DC, 100 W 85 V AC - 264 V AC; 45 - 65 Hz	115047
Adapter D-Sub-socket, M12 plug	114858
Plug L Set for prefabricating the high voltage cable with flexible tube to connect the R50 bzw. EXR50 discharging electrode to the generator PCTL	103289

Article	Reference code
Plug Y Set for prefabricating the high voltage cable with flexible tube for 30 kV charging electrodes resp. modification set for charging pluy Y	117985
Electrode bracket with bow	101075
Electrode bracket with bow, with inserted nuts	108763
Cleaning brush	RBR22
Operating instructions (specify language)	BA-xx-9066

Please specify the article number when ordering.

A. Annex

A.1 Electrical property requirements of impression rollers when using Eltex GNH63 Printing Assists

The proper function of the ESA Electrostatic Printing Assist requires impression roller coatings with certain electrical properties.

In 2-layer impression rollers these properties are defined by two resistance values - the insulation resistance **R_i** and the total volume resistance **R_{vt}**.

In 3-layer impression rollers these properties are defined by three resistance values - the insulation resistance **R_i**, the total volume resistance **R_{vt}** and the conductor resistance **R_L**.

Insulation resistance R_i

When printing substrates which electrically insulate the impression roller from the grounded impression cylinder (e.g. high resistance films, composites or thick carton), or if the impression roller is lowered onto the former cylinder while the former rotates, safety considerations dictate that the insulation resistance **R_i** must be within the above range:

$$\mathbf{R_i = 0.5\ G\Omega \dots 1.5\ G\Omega}$$

This resistance range is valid for all other applications.

$$\mathbf{R_i = >1\ G\Omega.}$$

Total volume resistance R_{vt}

The total volume resistance **R_{vt}** is of crucial importance for the proper function of the ESA. The unrestricted ESA function is ensured with total volume resistance values in the range of

$$\mathbf{R_{vt} = 150\ k\Omega m \dots 600\ k\Omega m / \text{Impression roller length in meter}}$$

Depending on paper grade, coatings outside the Eltex specifications can still lead to satisfactory printing results. However, impression rollers with excessively low resistance can result in a fire in the printing unit and bad print in the edge zones. In impression rollers with excessively high resistance, the printing quality declines.

The responsibility for the use of such coatings rests solely with the operator and the coating maker.

The total volume resistance **R_{vt}** can only be determined properly on a special test bench. Measurements directly at the impression roller or in the actual printing machines are not possible.

Conductor resistance **RL**

RL < 1 kΩ.

The resistance **RL** of the conductive layer of a ready-made impression roller cannot be measured because the layer is not accessible. The impression roller manufacturer has to ensure that the coating is made according to the specifications.

On the other hand, the third resistance value of an impression roller coating - the surface resistance **Ro** - can be determined without a test bench. Extensive studies have shown that there is a correlation between the total volume resistance **Rvt** and the surface resistance **Ro**.

As an alternative to the specified **Rvt** range, a value for the surface resistance **Ro** can therefore be given.

Since this correlation also depends on the composition of the coating, the value of the surface resistance **Ro** corresponding to the required total volume resistance range can only be given after test bench measurements. These measurements must be carried out by the coating maker.

For each coating the coating maker informs the user of the surface resistance **Ro which corresponds to the required total volume resistance range **Rvt**.**

We recommend that the details on the surface resistance range are given on the works certificate of each impression roller.

This approach will allow the user/operator to make comparative assessments of the impression rollers by relying on these measurements.

To determine the resistance values **Ri** and **Ro** please refer to Annex A.2 resp. Annex A.3.

A.2 Measurement regulations for 2-layer impression rollers for Eltex GNH63 Printing Assists

Measurements are made with the Impression Roller Tester Type 6208 and the Measuring Bow Type 6230. The bow contacts of the tester must be moistened with normal tap water before every measurement. The required measurement values are given in Electrical property requirements of impression rollers (Annex A.1) and the certificate issued by the coating maker.

Fig 14:
Measuring set-up

- 1 insulator
- 2 conductive layer
- 3 grounded metal core (<math><10\text{ k}\Omega</math>)
- 4 measuring side A
- 5 measuring centre
- 6 measuring side B
- 7 measuring bow 6230
- 8 impression roller tester type 6208

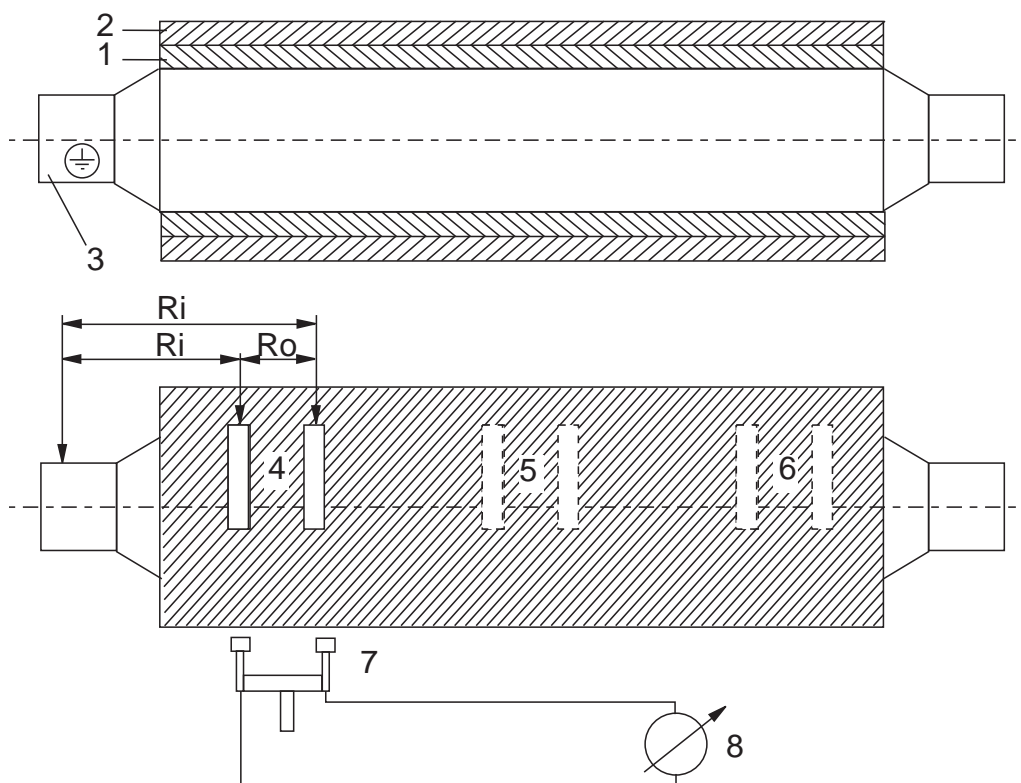

Surface resistance R_o

Test voltage = 100 V. The test values are to be determined at operating temperature. „Operating temperature“ means that the impression roller is installed in the printing unit and exposed to a dynamic line force load of approx. 10 N/mm. The impression roller is tested after reaching its operating temperature immediately after the roller has come to rest. The time interval between printing start-up and the time the operating temperature is reached must be specified by the coating maker.

Measurements must be taken on a minimum of 3 points: side A, middle and side B; a 20% error from the mean value is permissible.

Insulation resistance R_i

Test voltage = 500 V.

The value must be maintained throughout the entire temperature range.

A.3 Measurement regulations for 3-layer impression rollers for Eltex GNH63 Printing Assists

Measurements are made with the Impression Roller Tester Type 6208 and the Measuring Bow Type 6230. The bow contacts of the tester must be moistened with normal tap water before every measurement. The required measurement values are given in Electrical property requirements of impression rollers (Annex A.1) and the certificate issued by the coating maker.

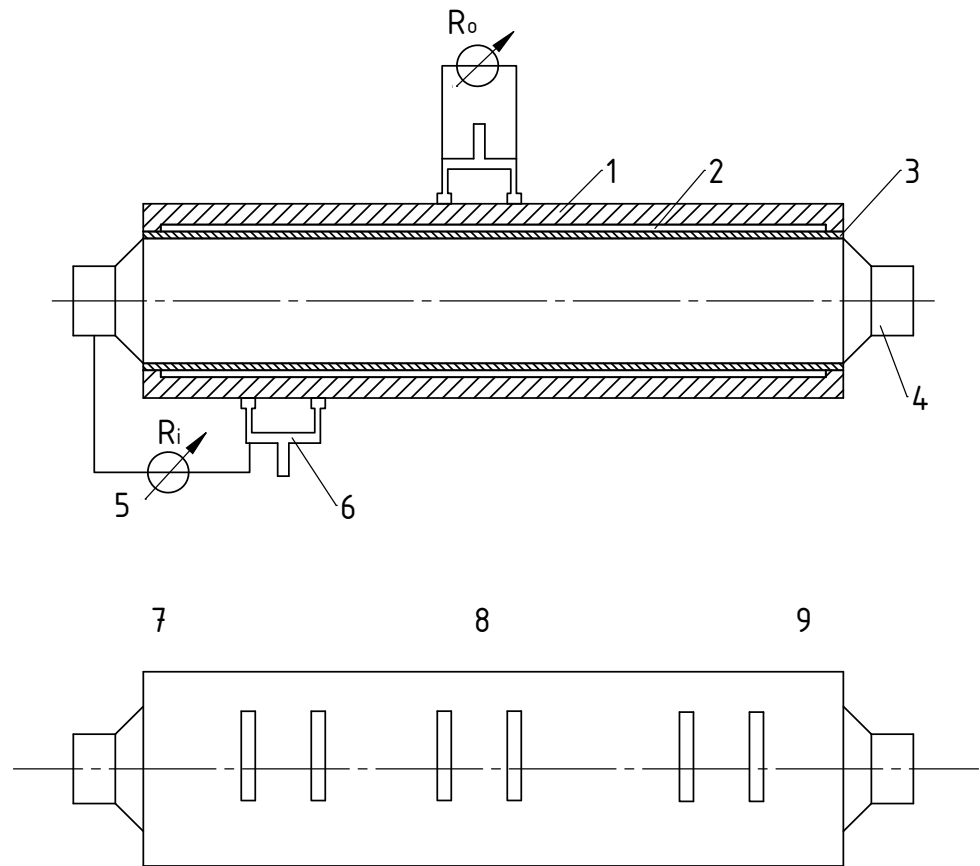

Fig. 15:
Measuring set-up

- 1 Semi-conductor
- 2 Conductive layer
- 3 Insulator
- 4 Grounded metal core, $R < 10 \text{ KOhm}$
- 5 Impression roller tester 6208
- 6 Measuring bow 6230
- 7 Side A
- 8 Centre
- 9 Side B

Z114166y

Surface resistance R_o

Test voltage = 100 V. The test values are to be determined at operating temperature. „Operating temperature“ means that the impression roller is installed in the printing unit and exposed to a dynamic line force load of approx. 10 N/mm. The impression roller is tested after reaching its operating temperature immediately after the roller has come to rest. The time interval between printing start-up and the time the operating temperature is reached must be specified by the coating maker.

Measurements must be taken on a minimum of 3 points: side A, middle and side B; a 20% error from the mean value is permissible.

Insulation resistance R_i

Test voltage = 500 V

The value must be maintained throughout the entire temperature range.

A.4 Test certificate impression roller coating

Name, address
of manufacturer of coating

Type of the impression roller coating: _____

1-layer- / 2-layer- / 3-layer-impression roller (delete as appropriate)

The coating has been tested by a dynamic resistance measurement on a test stand by contacting electrically the impression roller with a metallic cylinder. The power supply of the electrical voltage was made by a slip ring directly into the conductive layer put under the semi-conductive layer of the impression roller. The impression roller ran with a speed of 10 m/s and a line force of 10 N/mm. After having reached the production temperature, the total volume resistance **Rvt** or the rotary impression roller has been measured.

Measuring voltage: 500 V at the conductive layer against grounded metal cylinder.

Depending on the said conditions the total volume resistance **Rvt** of this coating is

Rvt = _____ kOhm referring to 1 meter length of impression roller.

According to Eltex measuring specifications for 1-, 2- or 3-layer impression rollers, a surface resistance measurement of this coating has been carried out after the test run. The value of the surface resistance was as follows

Ro = _____ MOhm.

This means the Eltex specification

Rvt = 150 kOhm...600 kOhm / length of impression roller

for the impression roller coatings of the above mentioned type is fulfilled for surface resistances in the area of

Ro = _____ MOhm ... _____ MOhm

Place

Date

Stamp/signature

A.5 Set-down regulations for impression rollers

When using a steel core:

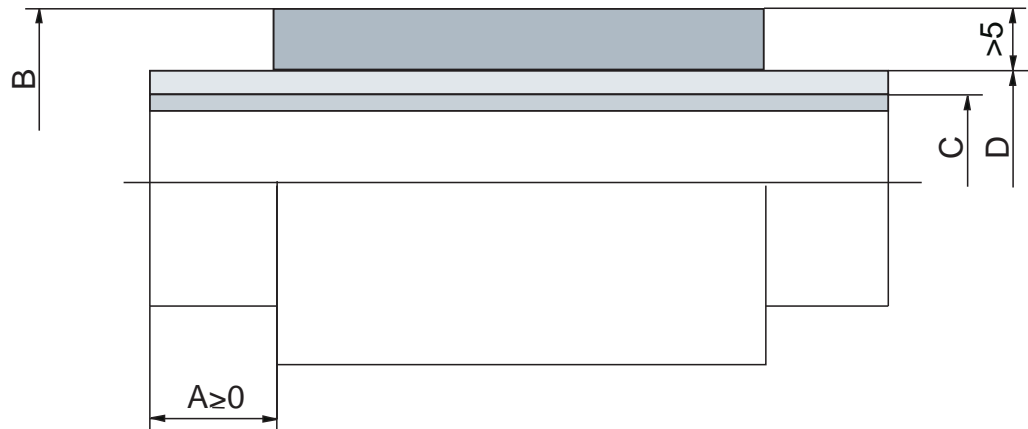

Fig 16:
Set-down
regulations when
using a steel core

Z00324y

When using glass fibre core

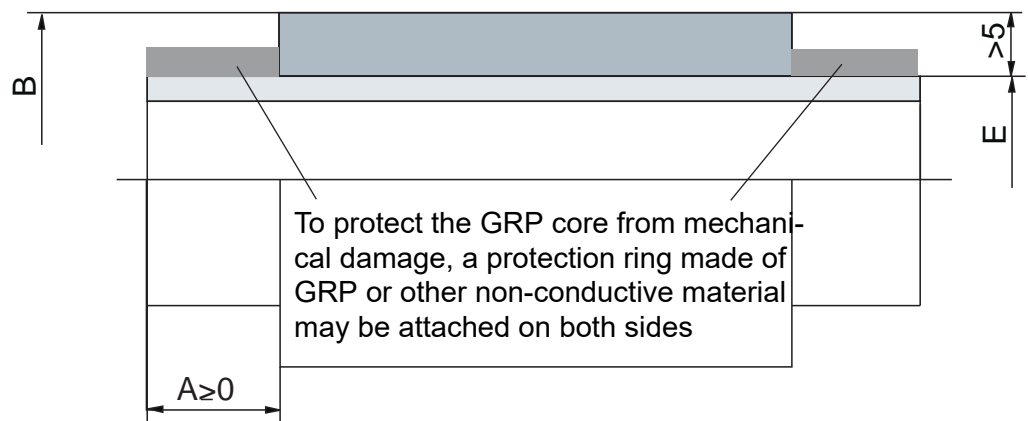

Fig 17:
Set-down
regulations when
using a glass fibre
core

Z00325y

- A set-down
- B \varnothing semi conductor
- C \varnothing steel core
- D \varnothing insulator
- E \varnothing glass fibre core

A.6 Setting down impression rollers in packaging printing

For maximum safety we recommend selecting the set-down width depending on the printing substrate in line with the following overview

Substrate	d substrate thickness	A substrate projection B impression roller projection
paper, carton	$d < 0.1 \text{ mm}$	any
	$0.1 \text{ mm} < d < 0.5 \text{ mm}$	$A = 10 \times d$
	$d > 0.5 \text{ mm}$	$A > 5 \text{ mm}$
film, composites	$d < 0.1 \text{ mm}$	$A > 5 \text{ mm}$ or $B > 1 \text{ mm}$
	$d > 0.1 \text{ mm}$	$A > 5 \text{ mm}$

Impression roller narrower than substrate:

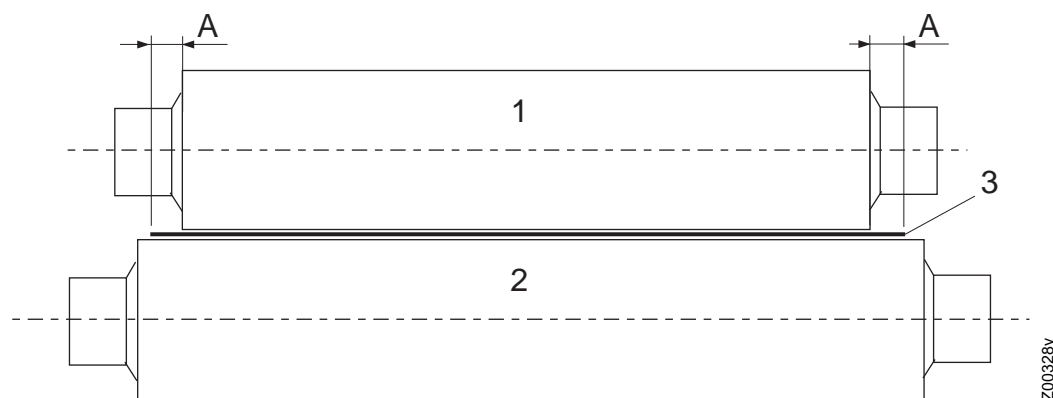

Fig 18:
Impression roller
narrower than
substrate

Impression roller wider than substrate

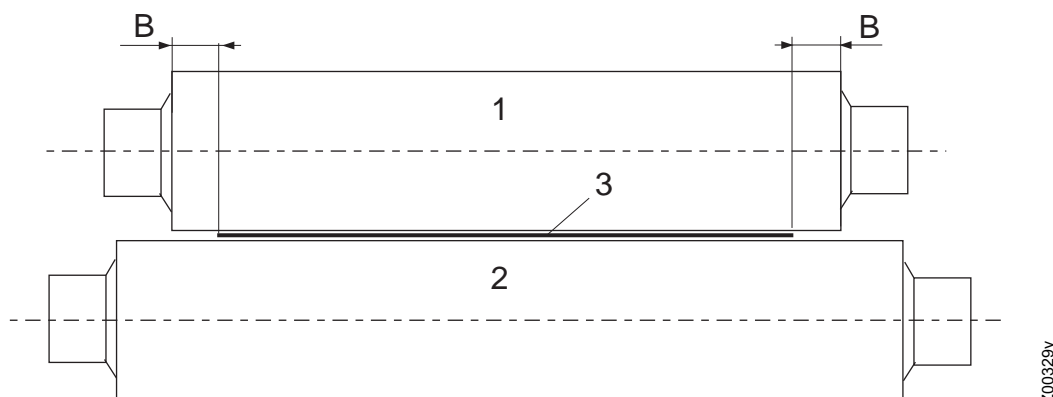

Fig 19:
Impression roller
wider than
substrate

- 1 Impression roller
- 2 printing cylinder
- 3 substrate
- A print substrate projecting edge
- B impression roller projecting edge

A.7 Pollution monitoring

Charging

The pollution monitoring is an additional function for monitoring the impression roller electrode; it is available in the generator variants with display and integrated fieldbus. For using this function, the parameter value for pollution monitoring must be set accordingly.

The current degree of the pollution is determined by comparing the parameterizable nominal resistance and the current load resistance of the charging. If this load resistance decreases, the electrode becomes conductive. In the case of insulating pollution, the value increases accordingly.

The calculation of the nominal resistance can be done by manually calculating the resistance value, reading out the current actual value for the load resistance of the charging or the automatic contamination calibration. It should be noted, however, that the calculation must be carried out with a new or freshly cleaned electrode.

The nominal resistance for the individual conditions must be determined separately. Particularly when using different substrates, it is necessary to determine the corresponding nominal resistance for reliable use of the pollution monitoring. With the automatic calibration of the pollution monitoring, the actual value of the load resistance is recorded and averaged over a period of 20 minutes.

The current level of pollution is a percentage value. If 0 % is displayed, the current value of the load resistance is equal to that of the nominal resistance. 100 % is a doubling or halving of the load resistance compared to the nominal resistance.

If the degree of pollution exceeds 80 %, the corresponding warning message is set. The error message for pollution occurs with a value greater than 100 %.

Discharging

A pollution monitoring of the discharge electrodes is not integrated. The detection of the pollution of the electrode is indirectly done via the actual values for the discharge current and voltage. If corresponding error messages occur for the discharge current and the discharge voltage, the electrode must be checked and cleaned accordingly.

A.8 Installation according to NEC

Type "B" (back side)

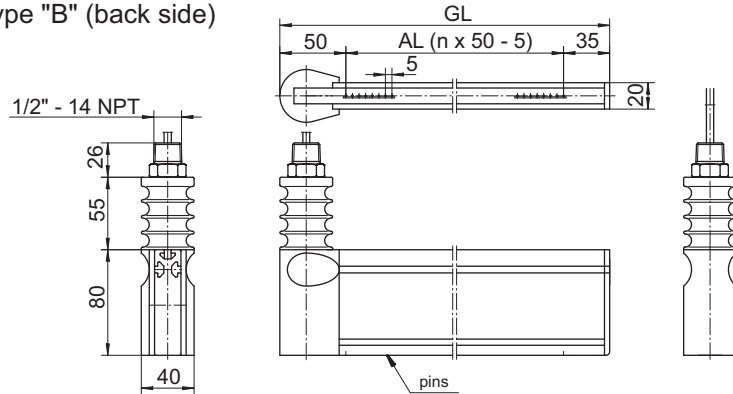

Type "W" (back side with angle)

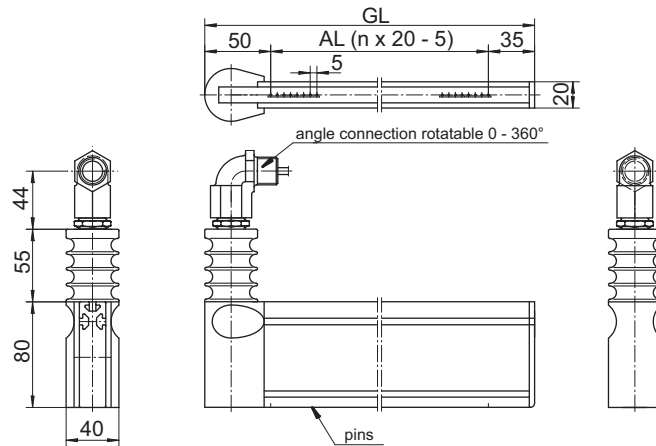

AL = active length
GL = total length

Delivery condition: reducing socket and protective hose connected to the thread 1/2" - 14 NPT of the bar (all types).

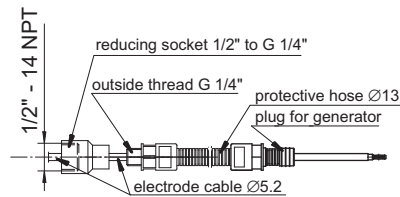

Protective hose connection dependent on the electrode bracket and the US or Canadian regulations by installations!

The installation must be in accordance with the National Electrical Code ANSI/NFPA 70, Article 504 and ANSI/ISA RP12.6. In Canada, the installation must be in accordance with Canadian Electrical Code, CEC Part 1.

Attention: Observe separate mounting instructions!

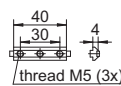

Sliding nuts
Item no. 100876
1m GL and below = 2 off
2m GL and below = 3 off
3m GL and below = 4 off
4m GL and below = 5 off

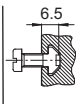

Plastic bolts
e.g. Item no. KSR 00015
Max. bolt depth 6.5 mm
Torque 0.4 Nm; Secure
bolts against working
loose (e.g. Loctite 243)

Fig 20:
Charging
electrode
EXR130US

Fig 21:
Discharging
electrode
EXR50US

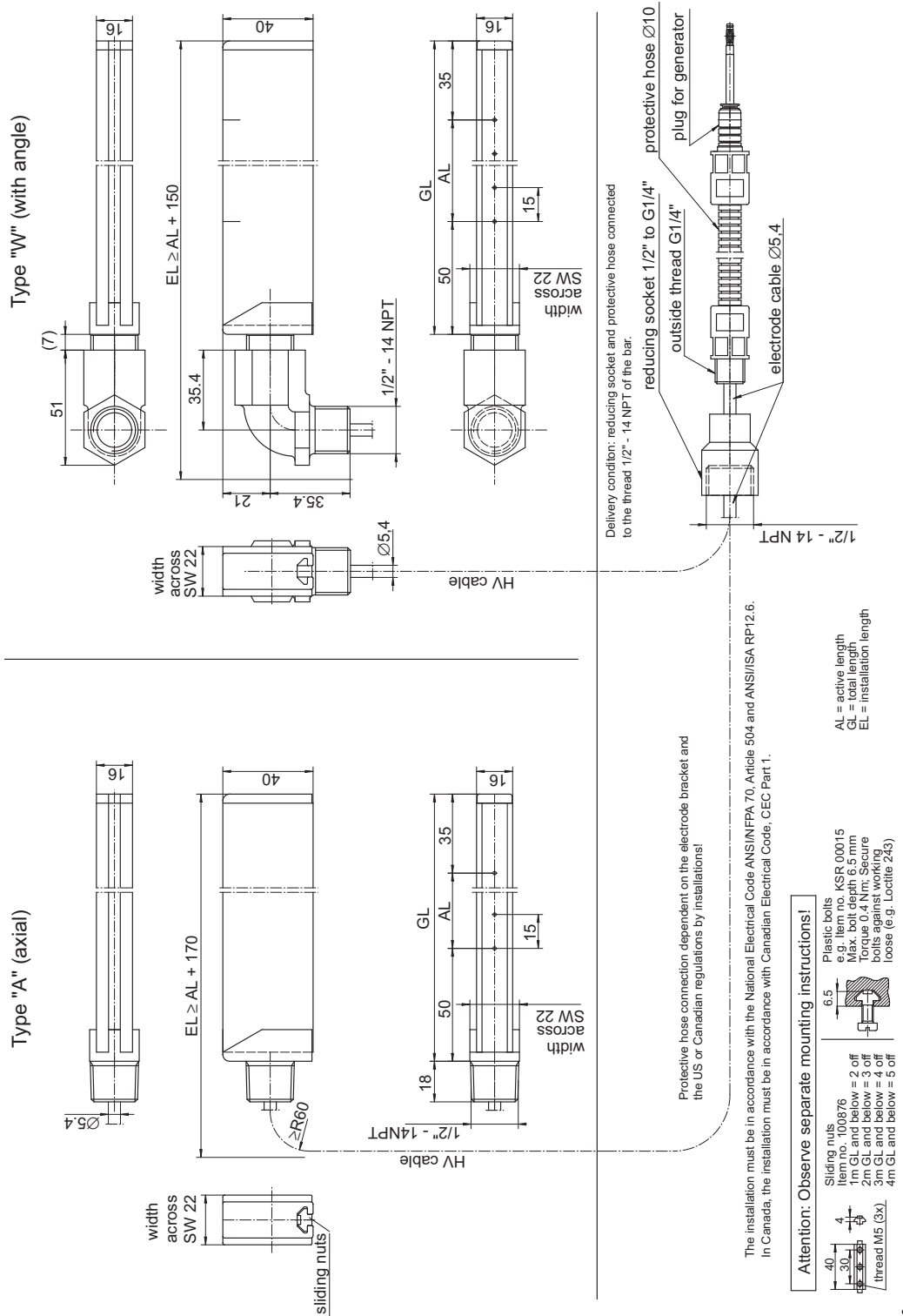
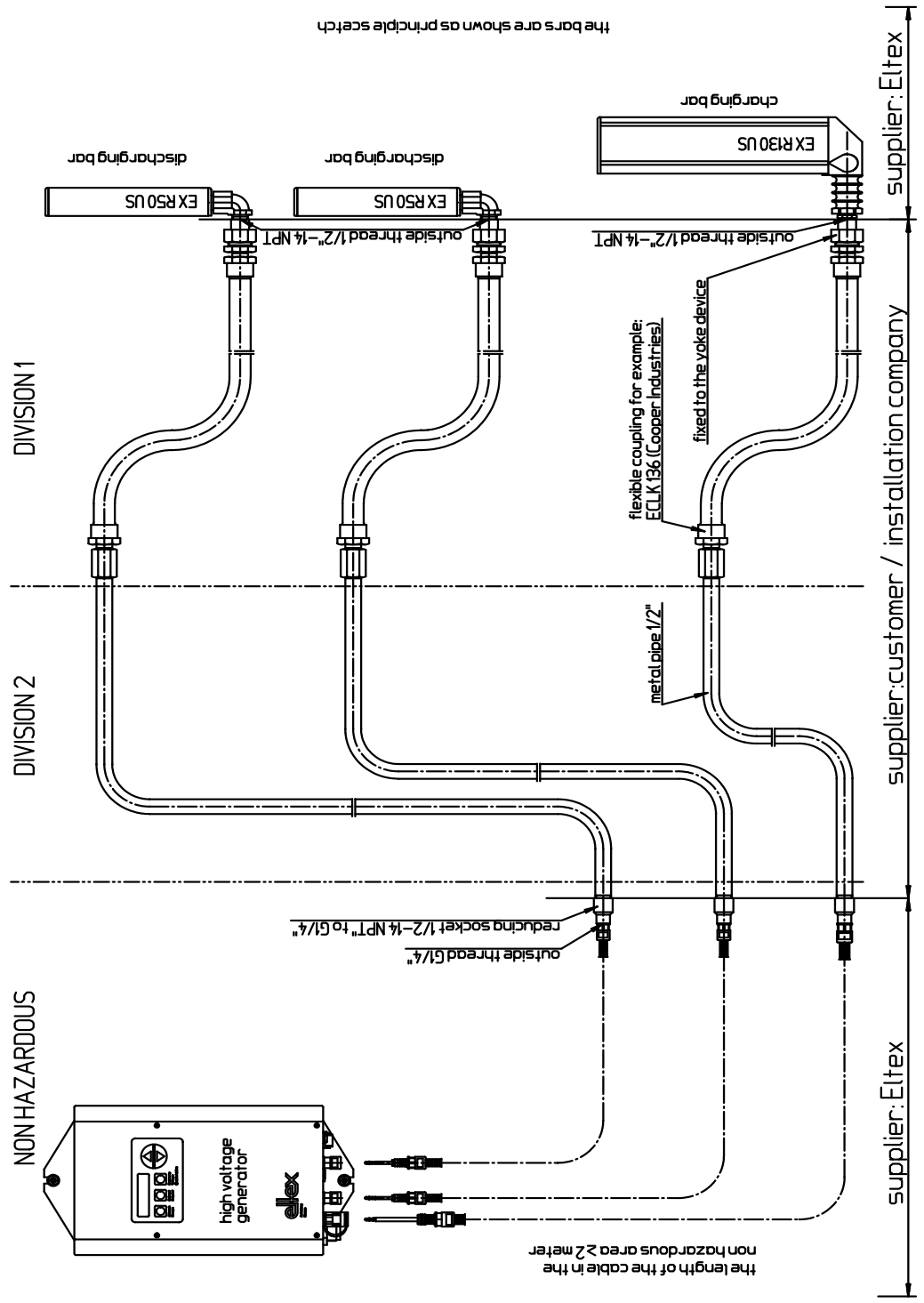
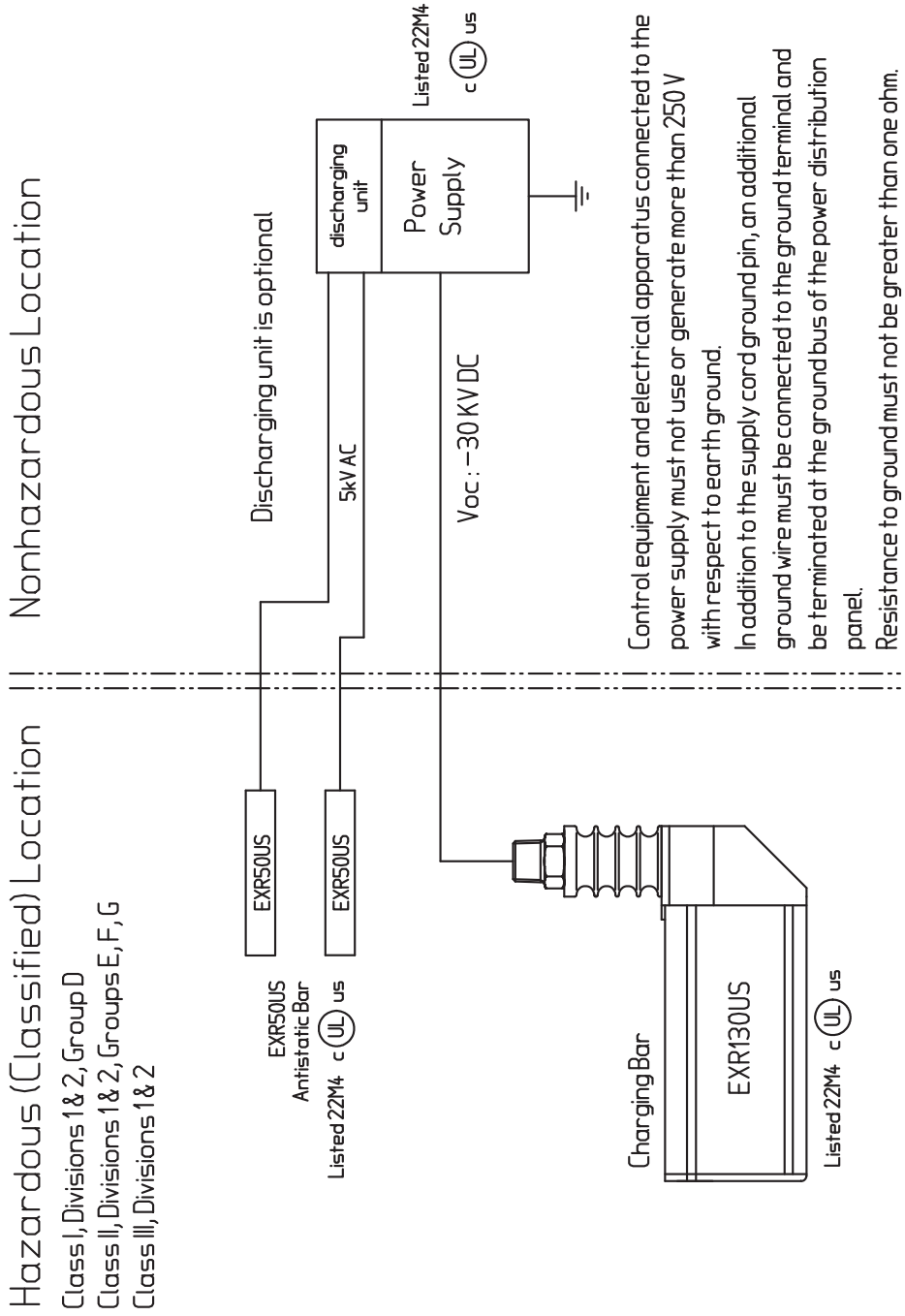

Fig 22:
installation
according to NEC



12628K3b

Fig 23:
Control drawing
GNH63 with anti-
static electrode
supply



The installation must be in accordance with the National Electrical Code ANSI/NFPA 70, Article 500
In Canada, the installation must be in accordance with Canadian Electrical Code, CEC Part 1.

13720X4b

Eltex offices and agencies

The addresses of all
Eltex agencies can be
found on our website at
www.eltex.de



z01007y



Eltex-Elektrostatik-Gesellschaft mbH
Blauenstraße 67-69
79576 Weil am Rhein | Germany
Phone +49 (0) 7621 7905-422
eMail info@eltex.de
Internet www.eltex.de